



MBTA Engineering Directive

ED-26-001

Subject: **Transit Track Clearance Requirements**

Date Issued: June 30, 2026

**APPROVED
BY:**

Signed by:
Rodney DeLisle
128639DD5A5E443...

Rodney DeLisle, PE
Deputy Chief of Technical Engineering and Design

ADMINISTRATIVE INFORMATION

- This Engineering Directive (ED) is effective on the date of issuance.
- This ED is applicable to all current and future MBTA maintenance and capital projects, as well as Transit-Oriented Development (TOD) projects adjacent to MBTA property.
- The requirements contained herein will be incorporated into a future revision of the MBTA Design Standards and Guidelines (DSG) Manual.

PURPOSE

This Engineering Directive defines MBTA's transit vehicle clearance envelopes and outlines the process for determining the minimum required track clearances. When new structures or wayside equipment are introduced, or existing elements are modified or relocated within the roadway, clearances to the track structure must be evaluated to ensure safe vehicle passage.

SUPERSEDED DOCUMENTS

MBTA Manual of Guidelines and Standards (Revised 1977), Pages D3, D4, D5, D6, and C2.2

DIRECTIVE

The technical requirements, standards, and guidelines established by this Engineering Directive are provided on the following pages.

CONTACT INFORMATION

Email: Engineering@MBTA.com

Website: <https://www.mbta.com/engineering>

Transit Track Clearance Requirements

TABLE OF CONTENTS

1.	PURPOSE.....	2
2.	APPLICABILITY	2
3.	DEFINITIONS.....	2
4.	REVENUE VEHICLE DATA SHEETS	3
5.	CLEARANCE ASSESSMENTS.....	3
6.	MINIMUM REQUIRED CLEARANCES TO WAYSIDE EQUIPMENT.....	4
7.	MINIMUM REQUIRED CLEARANCES TO STRUCTURES.....	5
7.1	GENERAL.....	5
7.2	HORIZONTAL CLEARANCES.....	6
7.3	VERTICAL CLEARANCES	6
7.4	CLEARANCES TO PLATFORMS.....	7
8.	CAR BODY EXCESSES	9
8.1	CENTER AND END EXCESSES.....	9
8.2	SUPERELEVATION EXCESS.....	11
8.3	CAR BODY EXCESS SIGN CONVENTION	11
9.	UNDERCAR CLEARANCES	12
10.	TRACK CENTER SPACING.....	17
11.	SAFETY NICHES.....	17
APPENDIX A - REVENUE VEHICLE DATA SHEETS		18

1. PURPOSE

This Engineering Directive defines the MBTA's transit vehicle clearance envelopes and outlines the process for determining the minimum required track clearances. When new structures or wayside equipment are introduced, or existing elements are modified or relocated within the roadway, clearances to the track structure must be evaluated to ensure safe vehicle passage.

2. APPLICABILITY

This directive applies to all maintenance and capital projects on the MBTA's transit track system including the Blue, Green, Orange, Red, and Mattapan High Speed Lines. In the event that conditions warrant deviation from this directive, the Engineer of Record must submit a waiver request to the MBTA Chief Engineer or their designee for review and approval.

3. DEFINITIONS

Center Excess is the additional projection of the center of an on-track vehicles's car body, towards the inside of a curve, when fully or partially positioned on curved track.

Dynamic Car Body Clearance Envelopes define the extreme cross-sectional limits within which an on-track vehicle's car body may occupy when fully positioned on tangent (straight), level track. This envelope is subject to Center, End, and Superelevation Excesses when not fully positioned on tangent and level track.

Dynamic Truck Clearance Envelopes define the extreme cross-sectional limits within which a moving on-track vehicle's truck (bogie) may occupy. This envelope is not subject to Center, End, and Superelevation Excesses.

End Excess is the additional projection of the ends of an on-track vehicle's car body, towards the outside of a curve, when fully or partially positioned on curved track.

Limited Clearance Areas are areas on the roadway where there is insufficient space to maintain a 2-foot-wide personnel clearance envelope when moving on-track revenue vehicles pass a roadway worker's location, but where there are niches available as a place of safety.

Niches are recesses constructed in tunnel liner, retaining wall, fencing, or other similar wayside structures to provide an area of refuge for personnel to clear on-track revenue vehicles.

No Clearance Areas are areas on the roadway where there is insufficient space to maintain a 2-foot-wide personnel clearance envelope when moving on-track revenue vehicles pass the roadway worker's location and where there is no place of safety available.

Personnel Clearance Envelope refers to the 2-foot wide by 6.5-foot tall cross-section area used to establish an area of refuge from on-track revenue vehicles.

Running Clearance is the distance maintained between the Dynamic Car Body Clearance Envelope (adjusted for local track geometry) or the Dynamic Truck Clearance Envelope, and wayside equipment or structures.

Static Car Body Clearance Envelopes define the extreme cross-sectional limits within which a stationary on-track vehicle's car body occupies when fully positioned on tangent and level track. This envelope is subject to Center, End, and Superelevation Excesses when not fully positioned on tangent, level track.

Superelevation Excess is the additional projection of any point of an on-track vehicle's car body, towards the low rail side of the track, when fully or partially positioned on superelevated track.

Wayside Equipment Clearance Envelopes define the cross-sectional limits to which wayside equipment may be installed on tangent, level track. No wayside equipment shall be installed within this envelope except as described herein. This envelope is subject to Center, End, and Superelevation Excesses when not fully positioned on tangent, level track.

4. REVENUE VEHICLE DATA SHEETS

Revenue vehicle data sheets are included in **Appendix A** of this document to provide clearance envelopes, general arrangement details, and car body excess tables for the system's revenue vehicles. These sheets shall be used to establish the minimum required clearances to wayside equipment and structures as required herein.

Clearances on the Mattapan High Speed Line shall be designed based on the Green Line Type 9 vehicle.

5. CLEARANCE ASSESSMENTS

Whenever new wayside equipment or structures are introduced within the roadway, or existing wayside equipment or structures are relocated or modified, the designer shall perform a clearance assessment to verify that the minimum required clearances are accurately calculated and field verified. At a minimum, the clearance assessment shall include the following:

- a. Confirmation with Maintenance of Way (MOW) of the existing track geometry at the proposed work location, including curve radius, superelevation, and gauge.
- b. Confirmation that sufficient wayside space is available through field investigation using hand measurements and/or LiDAR scanning.
- c. Submission of all clearance assessment documentation, including calculations, field investigation reports, LiDAR data, and any other supporting materials for MOW review and approval prior to installation.
- d. Post-installation verification, conducted in cooperation with MOW, confirming through field measurements that the minimum clearances, as required herein, are maintained prior to resuming revenue operations.

6. MINIMUM REQUIRED CLEARANCES TO WAYSIDE EQUIPMENT

For the purposes of this directive, wayside equipment shall include platform canopies, signage, cabling, conduits, pull-boxes, greasers, switch machines, security cameras, call boxes, signal anchors, radio equipment, lighting fixtures, plumbing, and other similar elements.

Wayside equipment clearance envelopes define the cross-sectional limits to which wayside equipment may be installed to on tangent and level track. These envelopes are derived by offsetting the dynamic clearance envelopes (for both the car body and truck) by 6-inches, representing the minimum running clearance for wayside equipment. Where roadway constraints prevent achieving this minimum, an absolute minimum running clearance of 3-inches may be permitted with written approval from MOW.

Where wayside equipment is located adjacent to curved and/or superelevated track, wayside equipment clearance envelopes associated with the dynamic car body clearance envelopes must be adjusted to account for car body excesses in accordance with **Section 8**. Wayside equipment clearance envelopes associated with dynamic truck clearance envelopes do not need to be adjusted to account for the effects of local track geometry.

Contact (third) rail, restraining rail, switch cover guards (housetops), and mechanical trip-stop arms are exceptions to these requirements, and thus are permitted to occupy wayside equipment clearance envelopes as prescribed by MOW and Signals & Communications Maintenance standards.

Within Green Line territory, the Type 10 vehicle dynamic truck clearance envelope need only be evaluated where the Category 1 and Category 2 dynamic car body clearance envelopes apply, since the Category 3 and 4 envelopes fully encompass the Type 10 vehicle dynamic truck clearance envelope. See **Section 9** for additional information.

The Type 10 vehicle clearance envelopes and their associated wayside equipment clearance envelopes do not need to be applied on the Mattapan High Speed Line, as Type 10 vehicles are not planned to operate within that territory.

7. MINIMUM REQUIRED CLEARANCES TO STRUCTURES

7.1 GENERAL

For the purposes of this directive, structures shall include bridges, tunnel walls, tunnel ceilings, columns, pier walls, utility poles, overhead contact system (OCS) poles, retaining walls, buildings, fencing, and other similar elements.

See **Section 7.4** for clearance requirements related to platforms, including both revenue and non-revenue platforms.

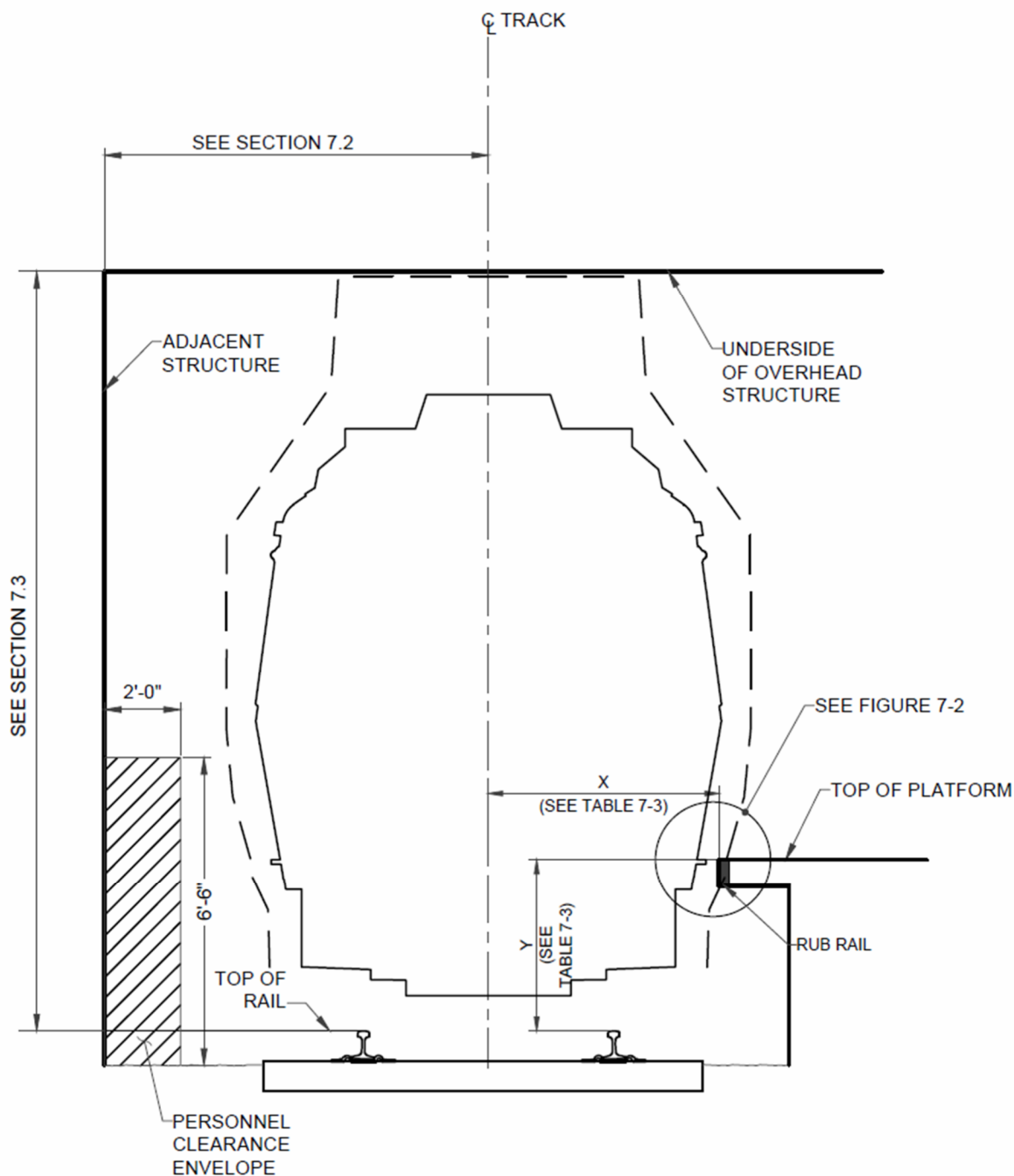

Figure 7-1: Structural Clearances in Tangent and Level Track

7.2 HORIZONTAL CLEARANCES

Roadway designs shall provide horizontal clearances in conformance with **Figure 7-1** and **Table 7-1**.

Table 7-1: Minimum Horizontal Clearances to Structures

Condition	Minimum Horizontal Clearance ⁽¹⁾
Preferred Minimum	10'-0"
Minimum	8'-6"
Absolute Minimum (Without Niches)	7'-6"
Absolute Minimum (With Niches)	6'-6"

(1) Values shown are for tangent and level track. Where structures are located along curved and/or superelevated track, these minimum clearance values shall be increased by an amount equal to the total car body excesses in accordance with **Section 8**.

7.3 VERTICAL CLEARANCES

Roadway designs shall provide vertical clearances in conformance with **Figure 7-1** and **Table 7-2**.

Table 7-2: Minimum Vertical Clearances to Structures

Condition	Minimum Vertical Clearance ⁽¹⁾
Preferred Minimum (OCS Territory)	21'-6"
Preferred Minimum (Non-OCS Territory)	18'-0"
Minimum (OCS Territory)	18'-0"
Minimum (Non-OCS Territory)	16'-6"
Absolute Minimum	15'-0"

(1) In locations with superelevated track, vertical clearances shall be measured from the high rail.

7.4 CLEARANCES TO PLATFORMS

Platform structures (excluding rub rail) shall always be positioned outside of revenue vehicle dynamic car body clearance envelopes (including adjustments for car body excesses).

Rub rail shall be installed along the full length of the platform structure and is permitted to encroach on the revenue vehicle dynamic car body clearance envelope (See **Figure 7-2**).

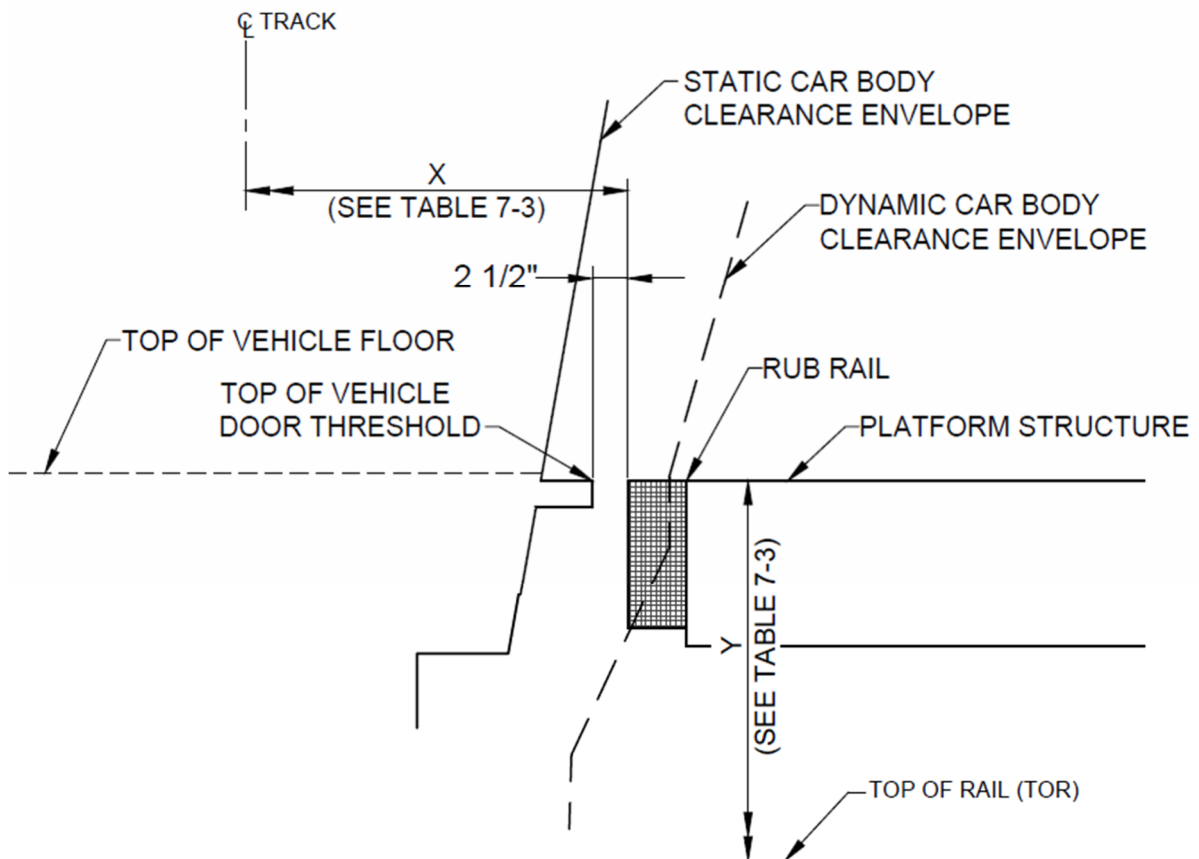

Figure 7-2: Station Platform to Revenue Vehicle Door Threshold in Tangent and Level Track

Rub rail serves to minimize vehicle damage in the event of contact with platforms and to adjust the horizontal gap between the platform edge and the static car body clearance envelope (adjusted for local track geometry) at the vehicle door threshold height.

Level boarding regulations require horizontal gaps of no more than 3-inches. To account for construction and maintenance tolerances, designers shall target a horizontal gap of 2.5-inches. To best achieve this target in tangent and level track, platform offsets to edge of rub rail provided in **Table 7-3** shall be used.

Table 7-3: Platform Design Heights and Offsets for Level Boarding in Tangent Track

Line	Platform Offset from Centerline of Track to Edge of Platform Rub Rail (X)	Platform Height from Top of New Rail to Top of Platform ⁽¹⁾ (Y)
Blue	4'-6"	3'-4"
Orange	4'-6"	3'-7 7/8"
Red	4'-11 3/8"	4'-0 3/8"
Green/MHSL ⁽²⁾	4'-5 7/8"	14"

(1) Platform height shall be measured to the top of the tactile panel truncated domes.

(2) Values are provided for planning purposes only. Level boarding has not yet been implemented on the LRT system. Existing LRT platform clearances in tangent track shall remain as currently specified (X = 4'-9" and Y = 8").

At platforms located along horizontally curved track, achieving a 2.5-inch gap at all vehicle door thresholds is not possible due to spatial constraints. In such cases, vehicle excesses must be considered and track-to-platform clearances adjusted, to ensure adequate separation. For concave platforms (outside of track curvature), the controlling offset is established by the gaps at the vehicle car body ends. For convex platforms (platforms located on the inside of track curvature), the controlling offset is established by the gap at the car body center. To best achieve regulatory level boarding requirements in these situations, the horizontal gap in platforms located along horizontally curved track are permitted to be reduced to no less than 1.5-inches at controlling offset locations.

Level boarding regulations require vertical gaps of no more than ± 0.5 -inches. To account for construction and maintenance tolerances, designers shall target a vertical separation of ± 0.25 -inches. Although this allows the door threshold to be either slightly above or below the platform, it is preferred that the door threshold be either level with or higher than the platform, as passengers are generally more accustomed to stepping up into a vehicle than stepping down. To best achieve level boarding regulations, platform design heights measured from the top of new rail provided in **Table 7-3** must be used.

Designers should note that maintenance tolerances, differences in door threshold position between vehicle fleets, and variability between door positions on the same vehicle will result in instances where the 2.5-inch target horizontal gap and/or zero vertical separation cannot be consistently achieved, even under ideal conditions.

8. CAR BODY EXCESSES

8.1 CENTER AND END EXCESSES

Center Excess (CE) and End Excess (EE) for revenue vehicles must be considered when radius of track falls below the following values:

- Blue Line – 8,000 feet
- Orange Line – 13,000 feet
- Red Line – 16,000 feet
- LRT System – 3,000 feet

See **Figure 8** for theoretical representation of CE and EE.

CE and EE values for MBTA revenue vehicles are provided in **Appendix A**.

Type 7, 8, and 9 vehicles, particularly the Type 7 vehicles, which consist of only two car body modules, exhibit greater CE and EE in curves than the Type 10 vehicles. Due to this, and because the Type 10 Category 2, 3, and 4 car body clearance envelopes (refer to **Section 9**) are more restrictive than the car body clearance envelopes for the Type 7, 8, and 9 vehicles, clearances in non-Category 1 areas must be calculated separately for both groups and superimposed; once for Type 7, 8, and 9 vehicles collectively, and once for Type 10 vehicles. For non-articulating on-rail vehicles other than MBTA revenue vehicles, CE and CE may be calculated using the following formulas.

$$CE = \frac{T^2}{8 * R}$$

Where:

CE = center excess, in inches
 T = truck or bogie center spacing, in feet
 R = radius of track, in feet

And,

$$EE = \frac{(L^2 - T^2)}{8 * R}$$

Where:

EE = end excess, in inches
 L = car body length, in feet
 T = truck center spacing, in feet
 R = radius of track, in feet

Note: When calculating EE for asymmetrical equipment (i.e., uneven projections between truck centers and vehicle ends), car body length (L) in the formula for EE shall be taken as twice the distance from the truck (or bogie) center to the end of equipment having the maximum projection from truck center, plus the truck center spacing.

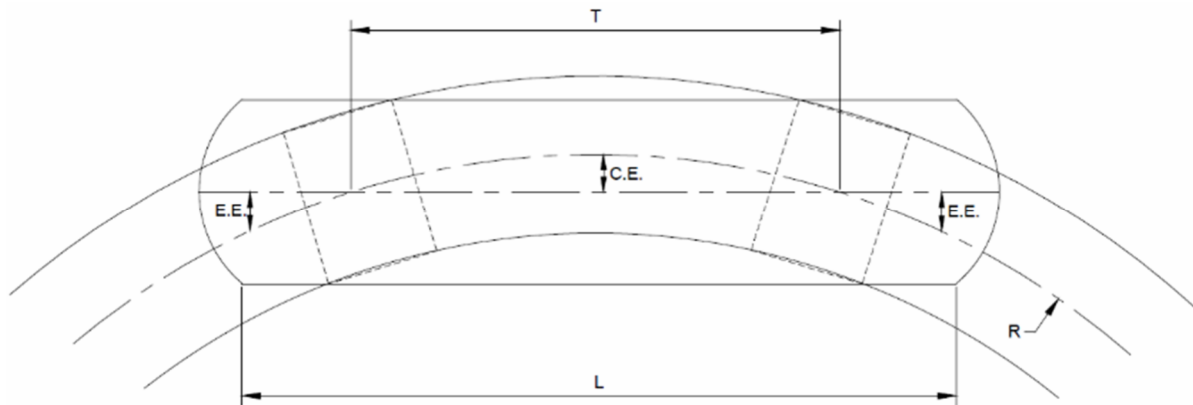

Figure 8: Theoretical Representation of Vehicle End Excess and Center Excesses

The application of CE and EE shall extend 50-feet beyond the point of curvature into tangent track to ensure adequate clearance throughout the transition area.

Particular attention shall be given to areas containing special trackwork where excesses to and from diverging moves may dictate the required clearances.

8.2 SUPERELEVATION EXCESS

When vehicles are fully or partially positioned on superelevated track, Superelevation Excess (SE) must be considered for clearance requirements.

SE shall be calculated based on the following equation.

$$SE = \frac{E * H}{G}$$

Where:

- SE = superelevation excess, in inches
- E = actual superelevation of the track, in inches
- H = height at which the SE is desired, in inches
- G = track gauge, in inches

The application of SE shall extend 50 feet beyond the limits of superelevation runoff into level track to ensure adequate clearance throughout the transition area.

8.3 CAR BODY EXCESS SIGN CONVENTION

The total car body excess shall be calculated as CE + SE for locations on the inside of a curve, and as EE + SE for locations on the outside of a curve. Sign conventions for car body excesses are as shown in **Table 8**.

Table 8: Sign Convention of Car Body Excesses

Excess Type	Inside of Curve / Low Rail Side for SE	Outside of Curve / High Rail Side for SE
Center Excess (CE)	Positive (+)	N/A
End Excess (EE)	N/A	Positive (+)
Superelevation Excess (SE)	Positive (+)	Negative (-)

9. UNDERCAR CLEARANCES

Type 10 vehicles require increased undercar clearances on qualifying vertical crest and sag curves, depending on the severity of the vertical curvature. To address this, the existing LRT system has been modeled and divided into track segments (See **Table 9**), each assigned to require specific Type 10 vehicle dynamic car body clearance envelope categories, as described below and illustrated in **Appendix A**.

- Category 1: Identical to the Type 7, 8, and 9 car body clearance envelope. This envelope contains 1'-1 1/8" wide by 3 1/8" tall notches located in the lower corners.
- Category 2: Exhibits reduced lower corner notches, 1'-1 1/8" wide by 1-1/2" tall.
- Category 3: Eliminates the lower corner notches.
- Category 4: Identical to the Category 3 envelope with the exception that the lower boundary limit extends down to the top of rail.

Track shall be designed with vertical geometry which allows for the Type 10 vehicle to remain within the Category 2 envelope at a minimum. Track geometry requiring the Category 3 envelope shall be considered an absolute minimum. Authorization to permit track geometry design which requires that the Type 10 vehicle exceed the Category 3 envelope should be considered in extreme cases only, and shall not be permitted in grade crossings, paved track, or other embedded track configurations.

For new or reprofiled track configurations, designers shall consult with Vehicle Engineering to determine the methods needed to assign Type 10 vehicle dynamic car body clearance envelope category limits based on the proposed vertical track geometry.

Table 9: Type 10 Dynamic Car Body Clearance Envelope Category Limits

Green Line Track	Direction	Start Chainmarker	End Chainmarker	Category
A Branch	EB	0+00	11+80	3
A Branch	EB	11+80	80+20	2
A Branch	EB	80+20	89+85	3
A Branch	EB	89+85	123+79	2
A Branch	EB	123+79	128+04	3
A Branch	EB	128+04	374+00	2
A Branch	WB	0+00	3+00	3
A Branch	WB	3+00	80+40	2
A Branch	WB	80+40	85+79	3
A Branch	WB	85+79	99+04	2
A Branch	WB	99+04	104+03	3
A Branch	WB	104+03	373+97	2
North Station Turnback Track 1	N/A	N/A	N/A	2
North Station Turnback Track 2	N/A	N/A	N/A	2
Park Street Loop	N/A	0+00	21+17	2
Government Center Loop	N/A	0+00	4+08	3
Brattle Loop	N/A	0+00	19+26	3
Kenmore Loop	N/A	0+00	6+25	4
B Branch	EB	0+00	3+75	3
B Branch	EB	3+75	148+09	2
B Branch	EB	148+09	153+01	3
B Branch	EB	153+01	180+32	2
B Branch	EB	180+32	187+08	3
B Branch	EB	187+08	226+47	2
B Branch	WB	0+00	2+53	3
B Branch	WB	2+53	51+68	2

Table 9: Type 10 Dynamic Car Body Clearance Envelope Category Limits (continued)

Green Line Track	Direction	Start Chainmarker	End Chainmarker	Category
B Branch	WB	51+68	56+67	3
B Branch	WB	56+67	90+34	2
B Branch	WB	90+34	95+33	3
B Branch	WB	95+33	125+00	2
B Branch	WB	125+00	131+05	3
B Branch	WB	131+05	147+43	2
B Branch	WB	147+43	153+53	3
B Branch	WB	153+53	161+75	2
B Branch	WB	161+75	167+05	3
B Branch	WB	167+05	182+15	2
B Branch	WB	182+15	191+53	3
B Branch	WB	191+53	227+02	2
Lake Street Yard	-	-	-	4 ⁽¹⁾
C Branch	EB	0+00	6+05	3
C Branch	EB	6+05	78+17	2
C Branch	EB	78+17	81+78	3
C Branch	EB	81+78	107+77	2
C Branch	EB	107+77	120+48	3
C Branch	EB	120+48	151+68	2
C Branch	EB	151+68	159+05	2
C Branch	WB	0+00	2+51	3
C Branch	WB	2+51	94+90	2
C Branch	WB	94+90	121+49	3
C Branch	WB	121+49	159+06	2
Chestnut Hill Connector (CHC) (EB Relay)	-	0+00	13+13	3
CHC (Switch B20 to B23)	-	0+00	1+70	3

(1) May require infrastructure modifications.

Table 9: Type 10 Dynamic Car Body Clearance Envelope Category Limits (continued)

Green Line Track	Direction	Start Chainmarker	End Chainmarker	Category
CHC (WB Relay)	-	0+00	12+93	3
CHC (CC Relay 1)	-	0+00	1+77	3
CHC (Ladder/Upper Ladder West)	-	0+00	11+72	4 ⁽¹⁾
CHC (Ladder/Upper Ladder East)	-	0+00	12+12	4 ⁽¹⁾
Reservoir Yard	-	-	-	4 ⁽¹⁾
D Branch	EB	0+00	21+25	2
D Branch	EB	21+25	37+33	3
D Branch	EB	37+33	44+81	2
D Branch	EB	44+81	59+88	3
D Branch	EB	59+88	74+12	2
D Branch	EB	74+12	99+84	3
D Branch	EB	99+84	115+23	2
D Branch	EB	115+23	123+24	3
D Branch	EB	123+24	457+08	2
D Branch	EB	457+08	461+31	3
D Branch	EB	461+31	495+69	2
D Branch	WB	0+00	11+93	2
D Branch	WB	11+93	15+41	3
D Branch	WB	15+41	19+79	2
D Branch	WB	19+79	25+07	3
D Branch	WB	25+07	33+35	2
D Branch	WB	33+35	37+13	3
D Branch	WB	37+13	71+10	2
D Branch	WB	71+10	76+77	3
D Branch	WB	76+77	84+37	2
D Branch	WB	84+37	89+89	3

(1) May require infrastructure modifications.

Table 9: Type 10 Dynamic Car Body Clearance Envelope Category Limits (continued)

Green Line Track	Direction	Start Chainmarker	End Chainmarker	Category
D Branch	WB	89+89	99+69	2
D Branch	WB	99+69	108+29	3
D Branch	WB	108+29	125+21	2
D Branch	WB	125+21	130+21	3
D Branch	WB	130+21	143+53	2
D Branch	WB	143+53	149+62	3
D Branch	WB	149+62	220+81	2
D Branch	WB	220+81	239+43	3
D Branch	WB	239+43	495+39	2
Riverside Yard	-	-	-	1
E Branch	EB	0+00	2+30	3
E Branch	EB	2+30	132+31	2
E Branch	WB	0+00	16+94	2
E Branch	WB	16+94	22+66	3
E Branch	WB	22+66	133+22	2
U Branch	EB	0+00	45+91	2
U Branch	WB	0+00	39+32	2
Mattapan High Speed Line	NB	0+00	134+90	1
Mattapan High Speed Line	SB	0+00	136+33	1
Mattapan Yard	-	-	-	1

10. TRACK CENTER SPACING

Horizontal spacing between track centerlines on tangent and level track shall conform to **Table 10-1**.

Table 10-1: Minimum Track Center Spacing on Tangent and Level Track

Mode	Minimum (feet)	Absolute Minimum (feet)
HRT	13	12
LRT	12	11

Where track curvature is present, track spacing shall be increased by an amount equal to the sum of the following components:

- CE of the line's revenue vehicle on the outside track,
- EE of the line's revenue vehicle for the inside track, and
- The difference in maximum SE between the two tracks:
 - Positive (+) when the outside track has higher superelevation, and
 - Negative (-) when the outside track has lower superelevation.

Under no circumstances shall the clearance between the dynamic car body clearance envelopes of vehicles on adjacent tracks be less than 6-inches, after accounting for track curvature and superelevation as described above. Any condition resulting in less than 6-inches of clearance may be allowed only with written approval from MOW.

11. SAFETY NICHES

Safety niches shall be provided wherever side clearances from the line's revenue vehicle are insufficient on both sides of the track bed to accommodate the personnel clearance envelope, including adjustments for track curvature and superelevation, over a continuous distance exceeding 100 feet.

Where required, niches shall be spaced at no more than 20-feet on-center, be 7-feet tall, 2-feet wide, and be as deep as necessary (1-foot deep minimum) to accommodate both the personnel clearance envelope and the line's dynamic car body clearance envelope, adjusted for local track geometry.

APPENDIX A - REVENUE VEHICLE DATA SHEET

STATIC CLEARANCE ENVELOPE		
	X (FROM C OF TRACK)	Y (ABOVE TOR)
1	1'-7 1/2"	0'-8 3/8"
2	1'-7 1/2"	1'-0"
3	2'-3 7/8"	1'-0 1/8"
4	2'-3 7/8"	1'-2 5/8"
5	3'-8 1/4"	1'-3 1/8"
6	3'-8 1/4"	2'-9 5/8"
7	4'-0"	2'-9 5/8"
8	4'-1 1/8"	3'-3 5/8"
9	4'-3 1/2"	3'-3 5/8"
10*	4'-3 1/2"	3'-4 3/4"
11	4'-1 3/8"	3'-4 3/4"
12	4'-7 1/8"	6'-1 1/2"
13	4'-2 3/8"	9'-9 3/4"
14	4'-2 1/4"	10'-0 3/4"
15	4'-0 3/4"	10'-0 3/4"
16	3'-10 1/4"	10'-4 7/8"
17	3'-5 1/8"	10'-8 7/8"
18	3'-4 1/4"	11'-1 1/4"
19	2'-10"	11'-6 5/8"
20	2'-10"	11'-10 7/8"
21	1'-5 3/8"	11'-10 7/8"
22	1'-2 5/8"	12'-7"

*TOP EDGE OF VEHICLE DOOR THRESHOLD

TOP OF PANTOGRAPH/
CATENARY WIRE
(HEIGHT VARIES)

C VEHICLE (SYMMETRICAL
ABOUT C)

DYNAMIC CLEARANCE ENVELOPE		
	X (FROM C OF TRACK)	Y (ABOVE TOR)
A	4' - 0 1/2"	1' - 3 3/8"
B	4'-0 7/8"	2'-5 1/2"
C	4'-4 7/8"	3'-2"
D	4'-4 7/8"	3'-4 7/8"
E	4'-9 3/8"	4'-8 1/4"
F	4'-10 7/8"	6'-0"
G	4'-10 3/4"	9'-8 7/8"
H	2'-10"	12'-7 7/8"
I	2'-6"	17'-9 1/2" MAX.*

*NOTE: INDICATES UP-STOP PANTOGRAPH HEIGHT

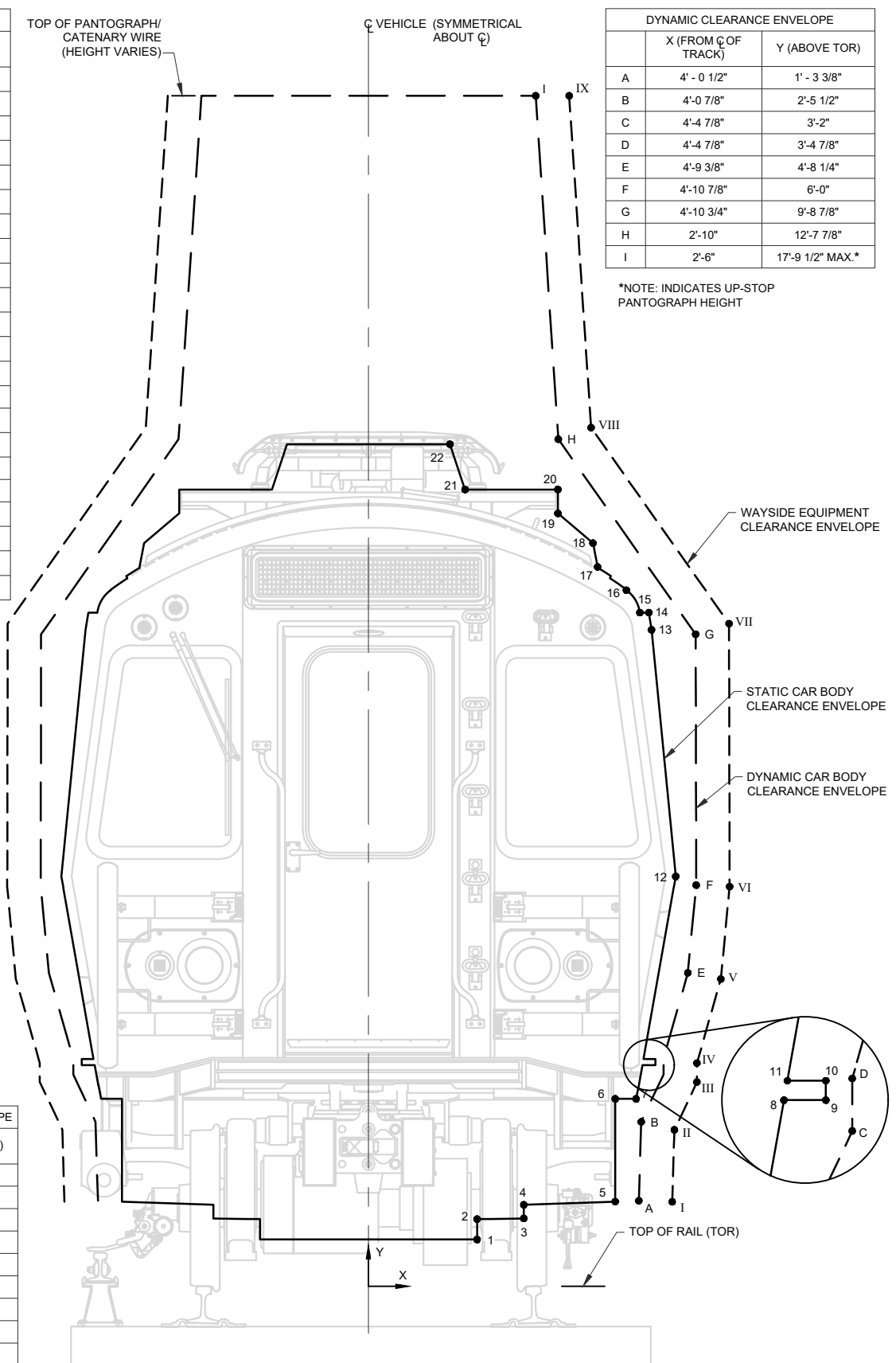

WAYSIDE EQUIPMENT CLEARANCE ENVELOPE		
	X (FROM C OF TRACK)	Y (ABOVE TOR)
I	4'-6 1/2"	1'-3 1/8"
II	4'-6 7/8"	2'-4"
III	4'-10 7/8"	3'-0 5/8"
IV	4'-10 7/8"	3'-4"
V	5'-3 1/4"	4'-7 1/8"
VI	5'-4 3/4"	9'-10 7/8"
VII	5'-4 3/4"	9'-8 7/8"
VIII	3'-4"	12'-10"
IX	3'-0"	17'-9 1/2" MAX.



REVENUE VEHICLE DATA SHEET

BLUE LINE #5 - CAR BODY CLEARANCE ENVELOPES

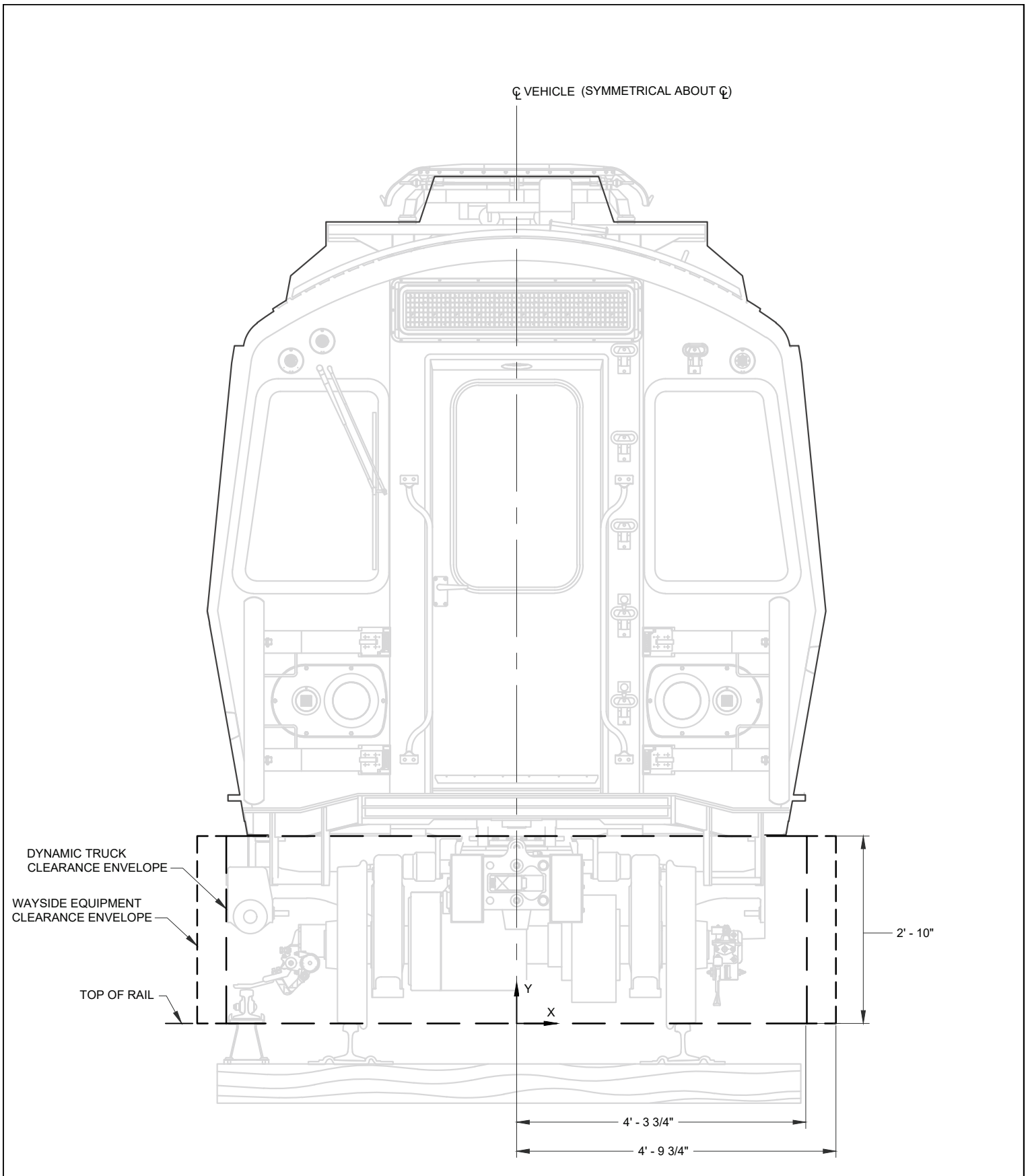

REVENUE VEHICLE DATA SHEET

BLUE LINE #5 - TRUCK CLEARANCE ENVELOPES

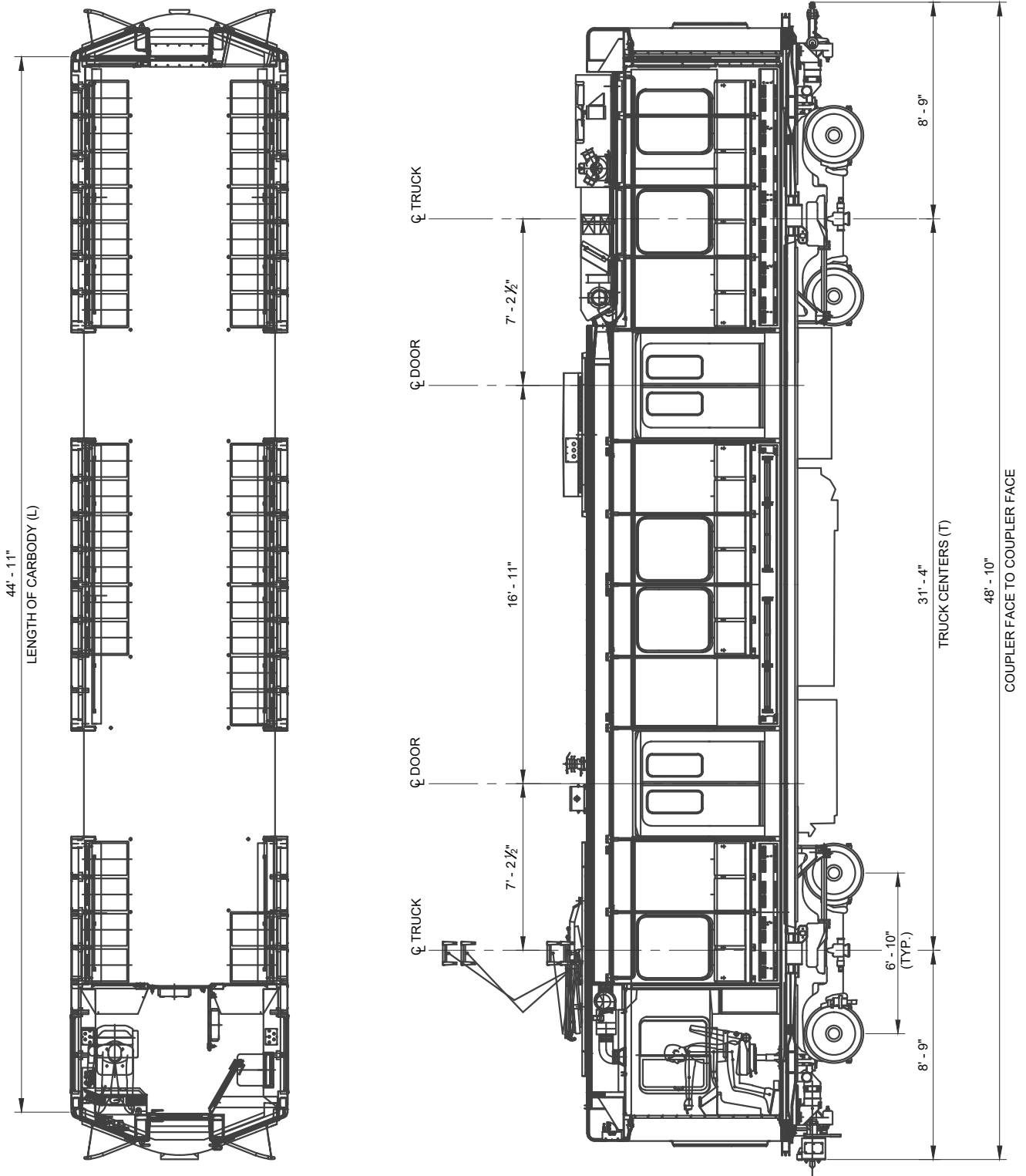

REVENUE VEHICLE DATA SHEET

BLUE LINE #5 - GENERAL ARRANGEMENT

Radius of Track (ft)	Center Excess (CE) (in)	End Excess (EE) (in)
50	30 1/2	29
75	20 1/2	18 1/2
100	15 3/8	14
125	12 3/8	11 1/8
150	10 3/8	9 1/4
175	8 7/8	8
200	7 3/4	7
225	6 7/8	6 1/4
250	6 1/4	5 5/8
300	5 1/4	4 5/8
400	3 7/8	3 1/2
500	3 1/8	2 3/4
600	2 5/8	2 3/8
750	2 1/8	1 7/8
1,000	1 5/8	1 3/8
1,500	1 1/8	1
2,000	3/4	3/4
3,000	1/2	1/2
4,000	3/8	3/8
5,000	3/8	1/4
6,000	1/4	1/4
7,000	1/4	1/4
8,000	1/4	1/8



REVENUE VEHICLE DATA SHEET

BLUE LINE #5 - CAR BODY EXCESS TABLE

STATIC CLEARANCE ENVELOPE		
	X (FROM C OF TRACK)	Y (ABOVE TOR)
1	4'-0 3/4"	2'-3"
2	3'-11 3/4"	2'-5 7/8"
3	3'-11 3/4"	2'-11 3/8"
4	4'-2 1/8"	3'-7"
5	4'-3 1/2"	3'-7 1/2"
6*	4'-3 1/2"	3'-8"
7	4'-1 3/4"	3'-8"
8	4'-7 1/2"	5'-2"
9	4'-7 1/2"	6'-2 1/8"
10	4'-2 3/4"	10'-2 7/8"
11	3'-11 1/8"	10'-7 5/8"
12	3'-6 7/8"	10'-10 1/2"
13	2'-11 7/8"	11'-3 1/8"
14	2'-5 1/2"	11'-6"
15	2'-0 3/4"	11'-8"
16	2'-0 3/4"	11'-9 3/8"
17	1'-10 1/8"	11'-10 3/8"
18	0'-11 1/4"	12'-0 7/8"
19	0'-2 3/8"	12'-1 5/8"
20	0'-2"	12'-3 5/8"

DYNAMIC CLEARANCE ENVELOPE		
	X (FROM C OF TRACK)	Y (ABOVE TOR)
A	4'-5 1/4"	2'-3"
B	4'-5 1/4"	2'-7 5/8"
C	4'-6 1/2"	3'-2 3/4"
D	4'-6 1/2"	3'-6 5/8"
E	4'-11 3/8"	5'-1 5/8"
F	4'-10 5/8"	10'-4 1/8"
G	2'-5 1/4"	11'-11 7/8"
H	0'-8 5/8"	12'-4 5/8"

*TOP EDGE OF VEHICLE DOOR THRESHOLD

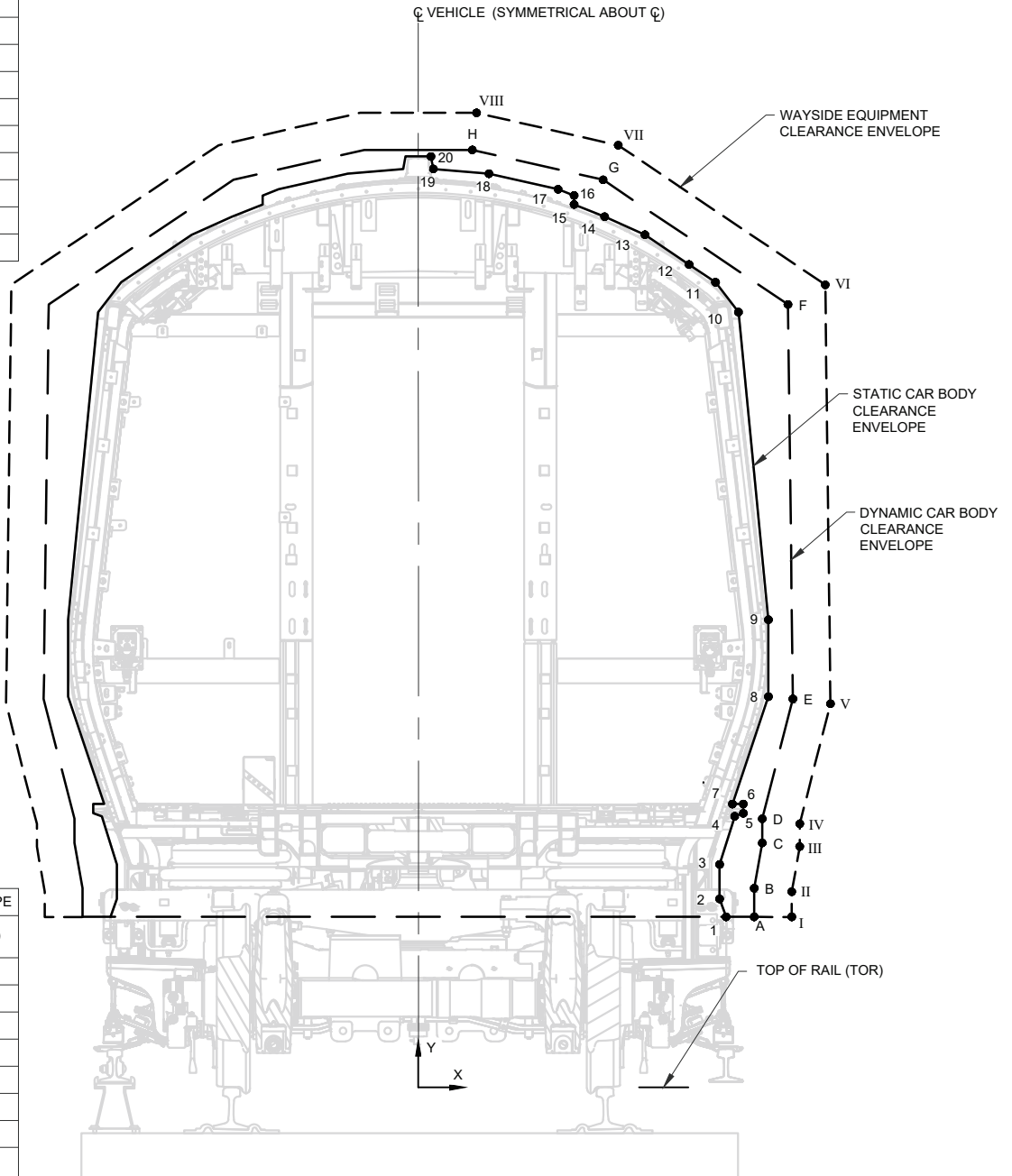

WAYSIDE EQUIPMENT CLEARANCE ENVELOPE		
	X (FROM C OF TRACK)	Y (ABOVE TOR)
I	4'-11 1/4"	2'-3"
II	4'-11 1/4"	2'-7"
III	5'-0 1/2"	3'-2 1/4"
IV	5'-0 1/2"	3'-5 3/4"
V	5'-5 3/8"	5'-0 7/8"
VI	5'-4 1/2"	10'-7 1/4"
VII	2'-7 3/4"	12'-5 3/8"
VIII	0'-9 1/4"	12'-10 1/2"



REVENUE VEHICLE DATA SHEET

ORANGE LINE #14 - CAR BODY CLEARANCE ENVELOPES

☉ VEHICLE (SYMMETRICAL ABOUT ☉)

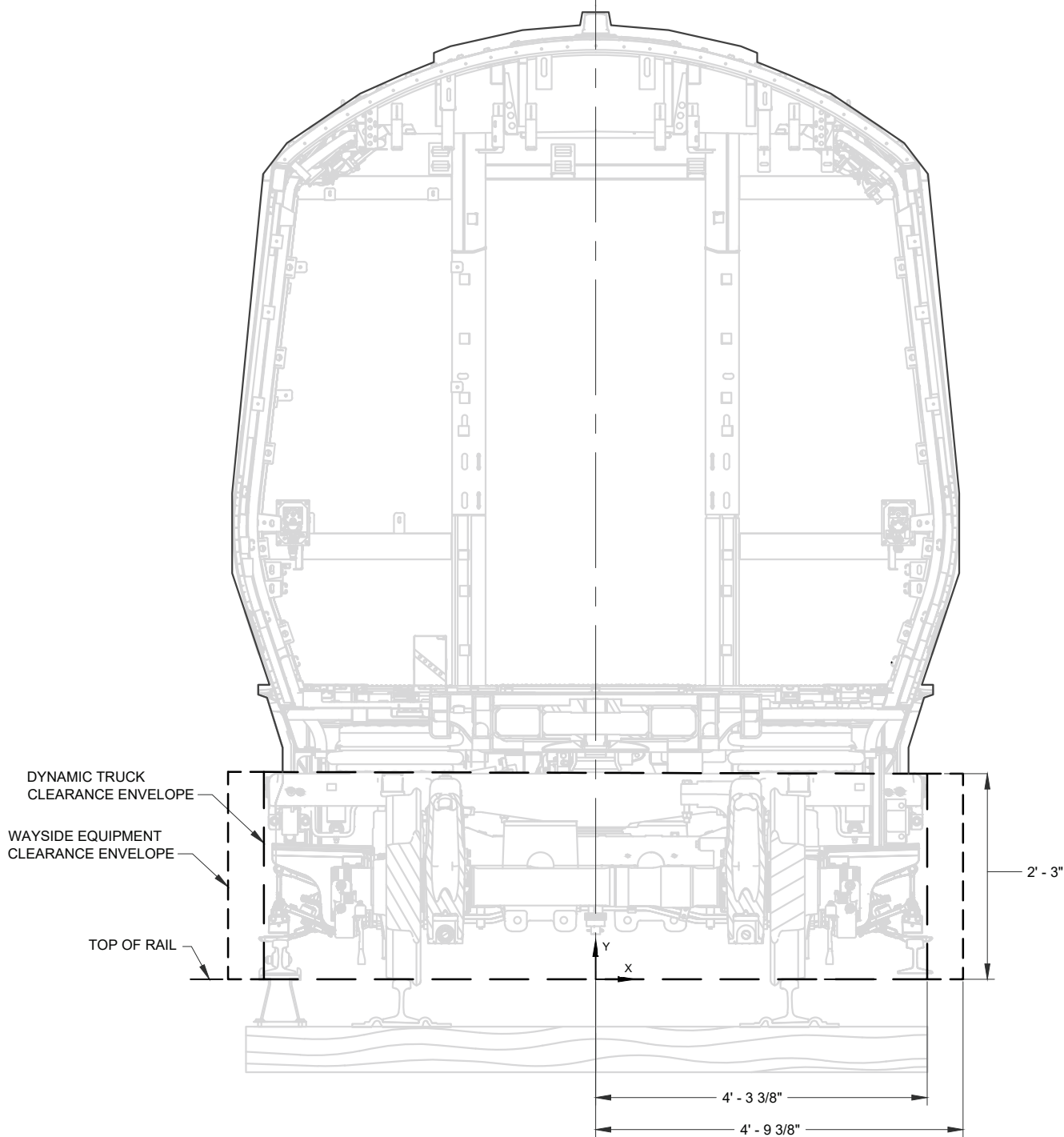

REVENUE VEHICLE DATA SHEET

ORANGE LINE #14 - TRUCK CLEARANCE ENVELOPES

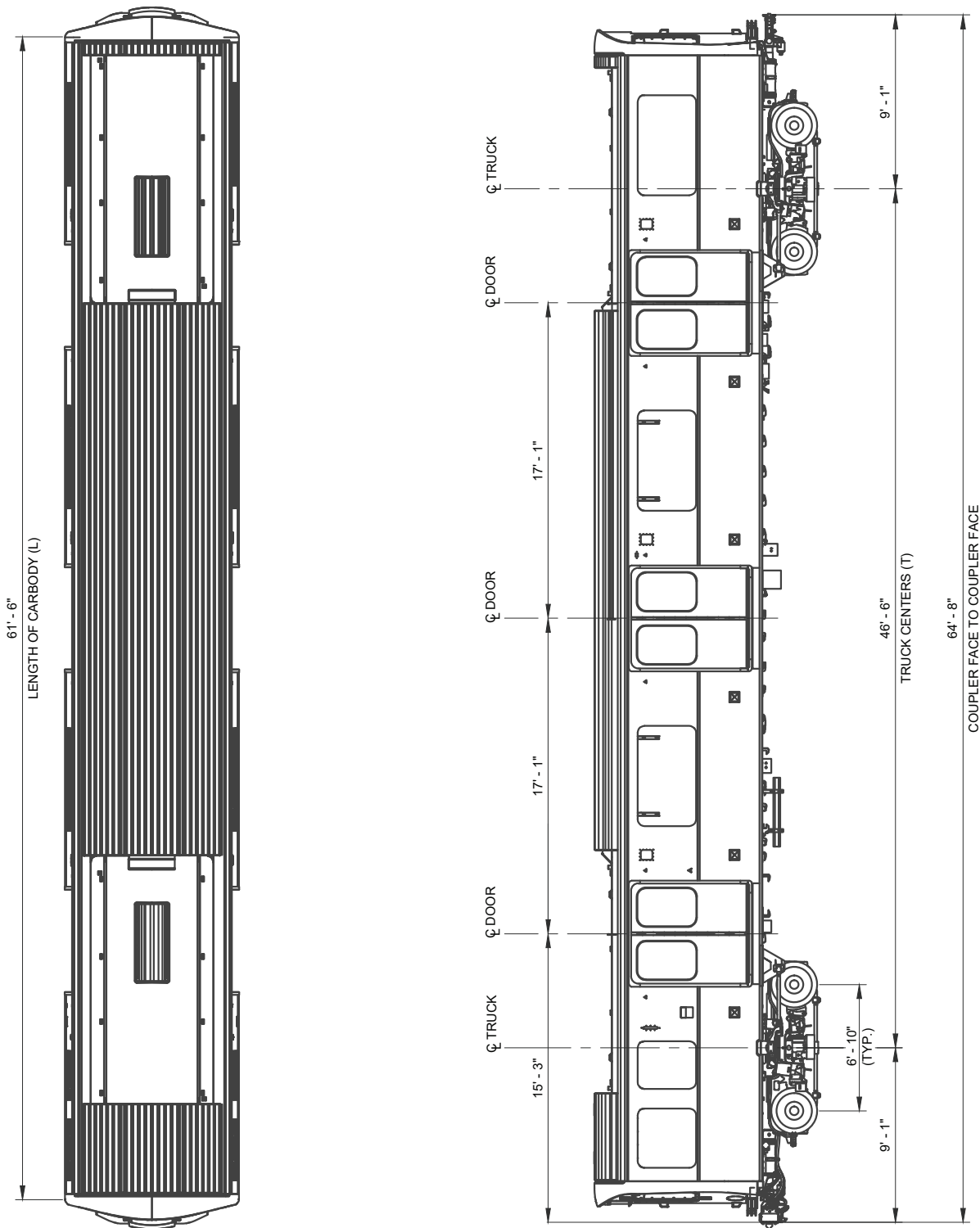

REVENUE VEHICLE DATA SHEET

ORANGE LINE #14 - GENERAL ARRANGEMENT

Radius of Track (ft)	Center Excess (CE) (in)	End Excess (EE) (in)
50	67 1/2	42 1/4
75	44 7/8	28 5/8
100	33 1/2	21 5/8
125	26 3/4	17 1/2
150	22 1/4	14 5/8
175	19	12 5/8
200	16 5/8	11 1/8
225	14 3/4	9 7/8
250	13 1/4	9
300	11	7 1/2
400	8 1/4	5 3/4
500	6 5/8	4 5/8
600	5 1/2	3 7/8
750	4 3/8	3 1/8
1,000	3 1/4	2 3/8
1,500	2 1/8	1 5/8
2,000	1 5/8	1 1/4
3,000	1 1/8	7/8
4,000	3/4	5/8
5,000	5/8	1/2
6,000	1/2	3/8
7,000	1/2	3/8
8,000	3/8	3/8
9,000	3/8	1/4
10,000	3/8	1/4
11,000	1/4	1/4
12,000	1/4	1/4
13,000	1/4	1/4



REVENUE VEHICLE DATA SHEET

ORANGE LINE #14 - CAR BODY EXCESS TABLE

STATIC CLEARANCE ENVELOPE		
	X (FROM C OF TRACK)	Y (ABOVE TOR)
1	4'-6"	3'-0 5/8"
2	4'-8 1/2"	3'-11 3/8"
3	4'-8 7/8"	3'-11 1/2"
4*	4'-8 7/8"	4'-0 3/4"
5	4'-7 5/8"	4'-0 3/4"
6	4'-11 1/4"	5'-3 3/4"
7	5'-0"	5'-8 5/8"
8	5'-0"	6'-10"
9	4'-10 3/8"	10'-7 1/8"
10	4'-6 3/4"	11'-0 1/8"
11	3'-11 3/4"	11'-4 3/8"
12	3'-0 3/8"	11'-9 1/2"
13	1'-10 1/8"	12'-2 3/8"
14	0'-11 1/4"	12'-4 7/8"
15	0'-2 3/8"	12'-5 5/8"
16	0'-2"	12'-7 1/2"

DYNAMIC CLEARANCE ENVELOPE		
	X (FROM C OF TRACK)	Y (ABOVE TOR)
A	5'-0"	1'-5"
B	5'-0"	4'-0 7/8"
C	5'-4 7/8"	5'-6 1/2"
D	5'-6 3/4"	10'-6 1/4"
E	5'-2"	11'-0"
F	4'-8 5/8"	11'-5"
G	3'-0 3/8"	12'-2"
H	0'-9 7/8"	12'-8 3/4"
I	0'-5 7/8"	12'-10 3/4"

*TOP EDGE OF VEHICLE DOOR THRESHOLD

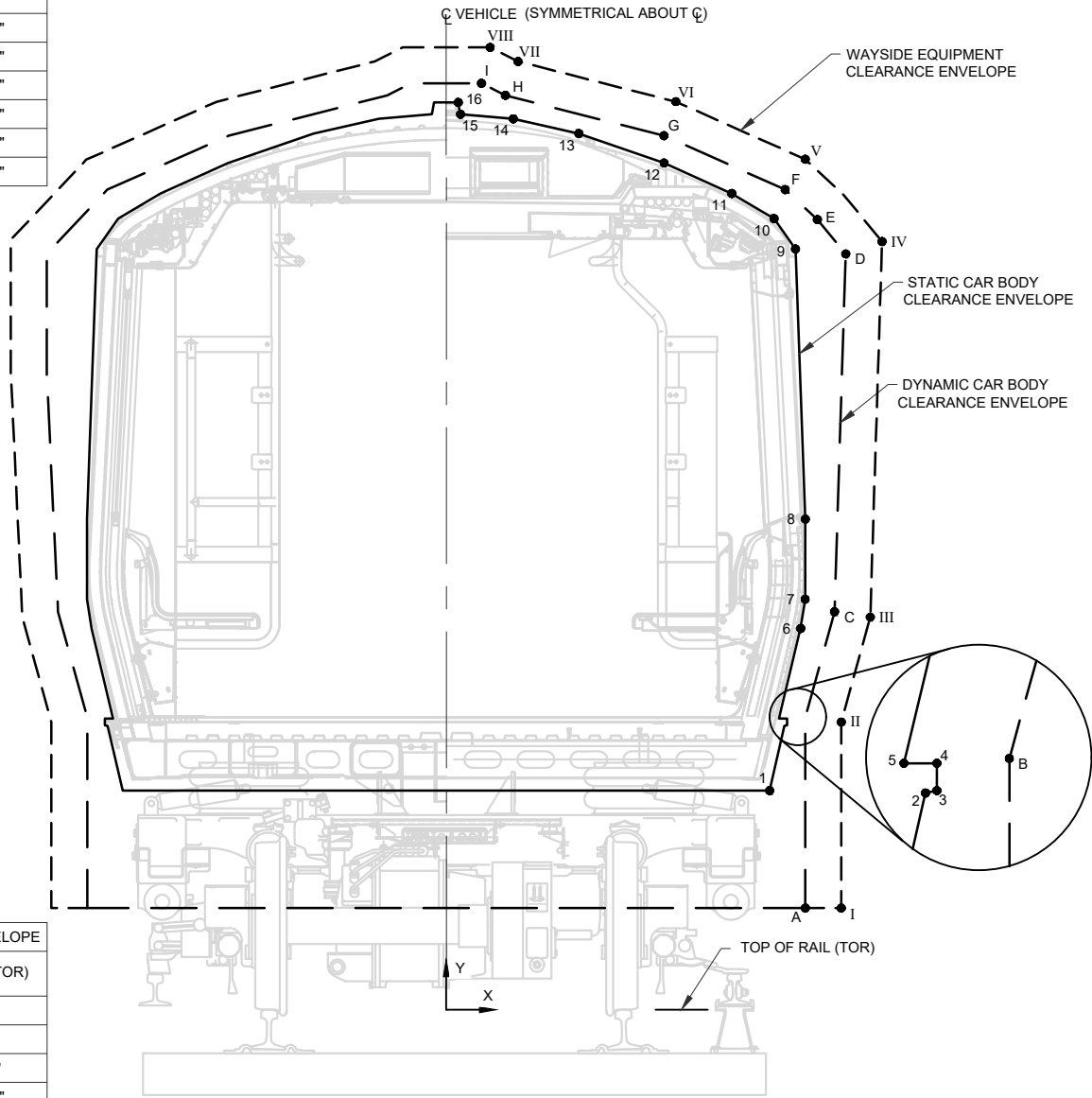

WAYSIDE EQUIPMENT CLEARANCE ENVELOPE		
	X (FROM C OF TRACK)	Y (ABOVE TOR)
I	5'-6"	1'-5"
II	5'-6"	4'-0"
III	5'-10 7/8"	5'-5 5/8"
IV	6'-0 7/8"	10'-8 3/8"
V	5'-0"	11'-10 1/8"
VI	3'-2 3/8"	12'-7 3/4"
VII	1'-0"	13'-2 3/8"
VIII	0'-7 3/8"	13'-4 3/4"



REVENUE VEHICLE DATA SHEET

RED LINE #4 (#1, 2, & 3 SIMILAR) - CAR BODY CLEARANCE ENVELOPES

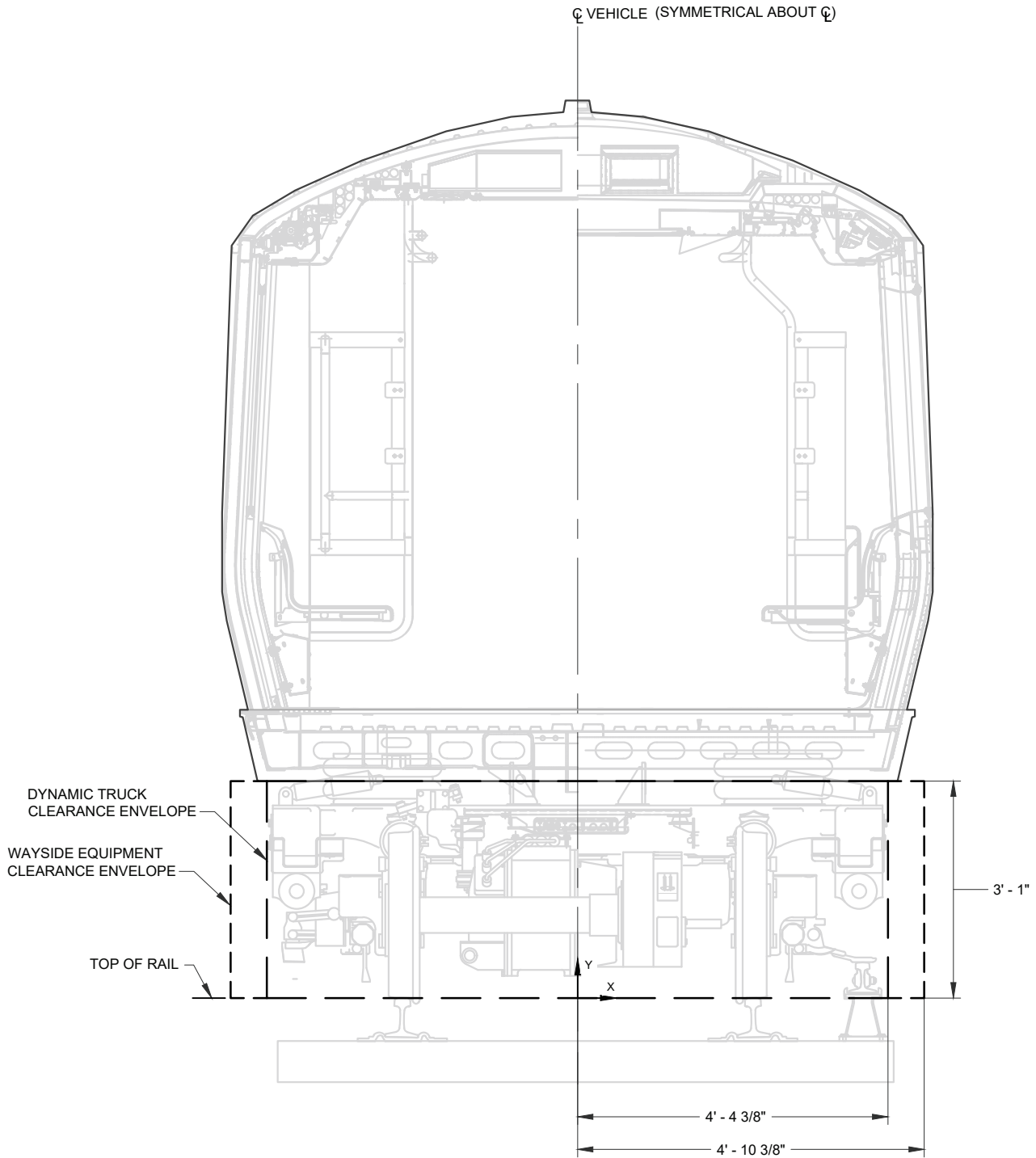

REVENUE VEHICLE DATA SHEET

RED LINE #4 (#1, 2, & 3 SIMILAR) - TRUCK CLEARANCE ENVELOPES

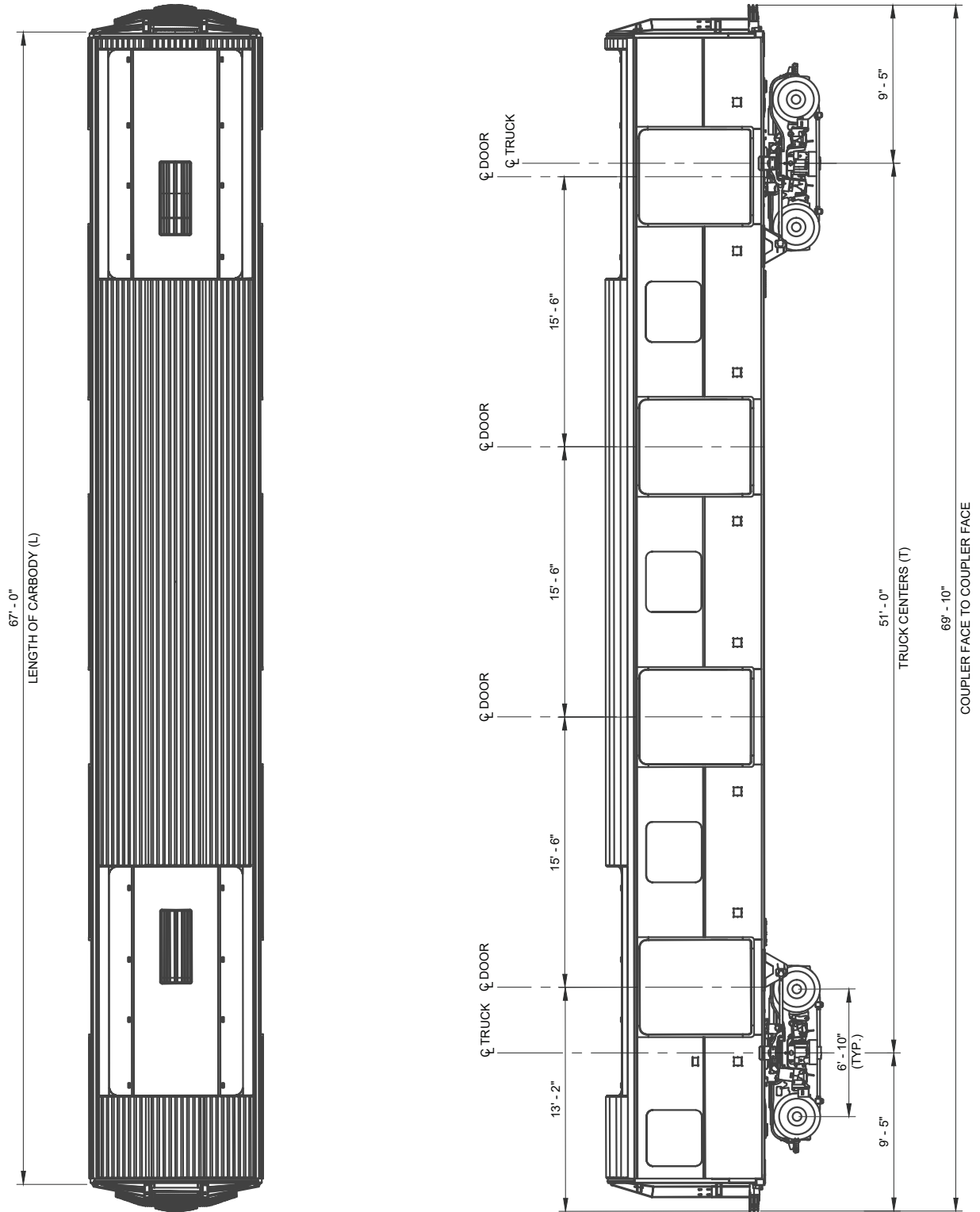

REVENUE VEHICLE DATA SHEET

RED LINE #4 (#1, 2, & 3 SIMILAR) - GENERAL ARRANGEMENT

Radius of Track (ft)	Center Excess (CE) (in)	End Excess (EE) (in)
50	81 1/2	45 5/8
75	54 1/8	31
100	40 1/2	23 1/2
125	32 3/8	19
150	27	16
175	23 1/8	13 3/4
200	20 1/4	12 1/8
225	17 7/8	10 7/8
250	16 1/8	9 3/4
300	13 3/8	8 1/4
400	10	6 1/4
500	8	5
600	6 5/8	4 1/4
750	5 3/8	3 3/8
1,000	4	2 5/8
1,500	2 5/8	1 3/4
2,000	2	1 3/8
3,000	1 3/8	7/8
4,000	1	3/4
5,000	3/4	1/2
6,000	5/8	1/2
7,000	5/8	3/8
8,000	1/2	3/8
9,000	1/2	3/8
10,000	3/8	1/4
11,000	3/8	1/4
12,000	3/8	1/4
13,000	1/4	1/4
14,000	1/4	1/4
15,000	1/4	1/4
16,000	1/4	1/8



REVENUE VEHICLE DATA SHEET

RED LINE #4 (#1, 2, & 3 SIMILAR) - CAR BODY EXCESS TABLE

STATIC CLEARANCE ENVELOPE		
	X (FROM C OF TRACK)	Y (ABOVE TOR)
1	4'-4"	0'-7 5/8"
2	4'-4"	5'-4"
3	4'-3 1/2"	6'-0 1/2"
4	4'-3 1/2"	8'-3 3/8"
5	4'-5 5/8"	8'-3 3/8"
6	4'-5 5/8"	8'-10 1/2"
7	4'-3 1/2"	8'-10 1/2"
8	4'-3 1/2"	9'-1 3/8"
9	3'-9 3/8"	10'-7 1/4"
10	2'-7 3/8"	11'-10"
11	0'-0"	11'-10"

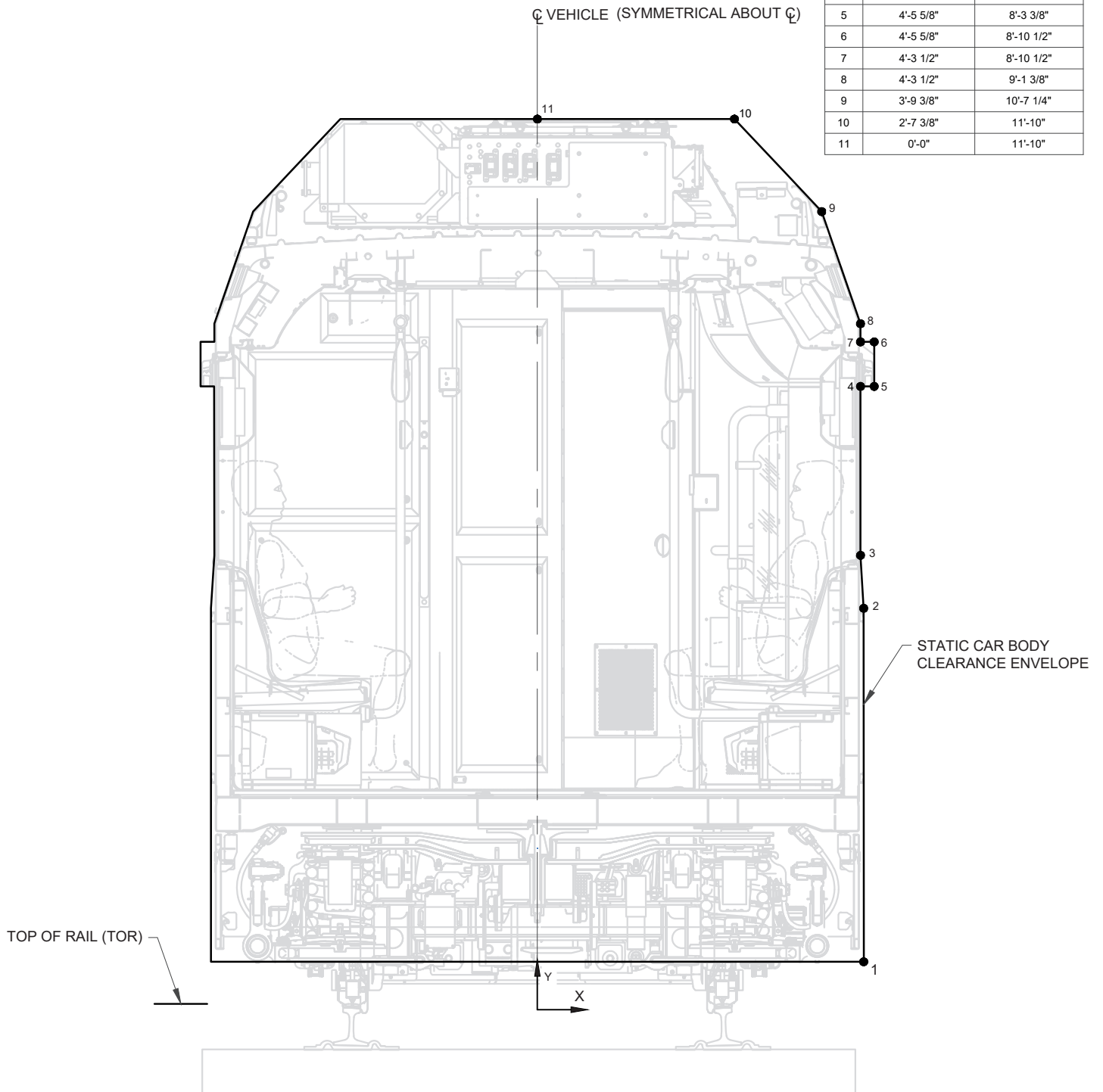

REVENUE VEHICLE DATA SHEET

GREEN LINE TYPE 7, 8, 9 & 10 - STATIC CAR BODY CLEARANCE ENVELOPE

DYNAMIC CLEARANCE ENVELOPE		
	X (FROM C OF TRACK)	Y (ABOVE TOR)
A	3'-3 1/2"	0'-2"
B	3'-3 1/2"	0'-5 1/8"
C	4'-4 5/8"	0'-5 1/8"
D	4'-8 3/4"	5'-1"
E	4'-8 1/2"	9'-1 5/8"
F	4'-3 1/4"	10'-5 1/4"
G	3'-2 1/4"	11'-8 1/8"
H	3'-2 1/4"	19' - 0" MAX*

WAYSIDE EQUIPMENT CLEARANCE ENVELOPE		
	X (FROM C OF TRACK)	Y (ABOVE TOR)
I	3'-9 1/2"	0'-2"
II	3'-9 1/2"	0'-5 1/8"
III	4'-10 5/8"	0'-5 1/8"
IV	5'-2 3/4"	5'-0 3/4"
V	5'-2 1/2"	9'-2 5/8"
VI	4'-8 5/8"	10'-8 1/4"
VII	3'-8 1/4"	11'-10 3/8"
VIII	3'-8 1/4"	19'-0" MAX.

*NOTE: INDICATES UP-STOP PANTOGRAPH HEIGHT

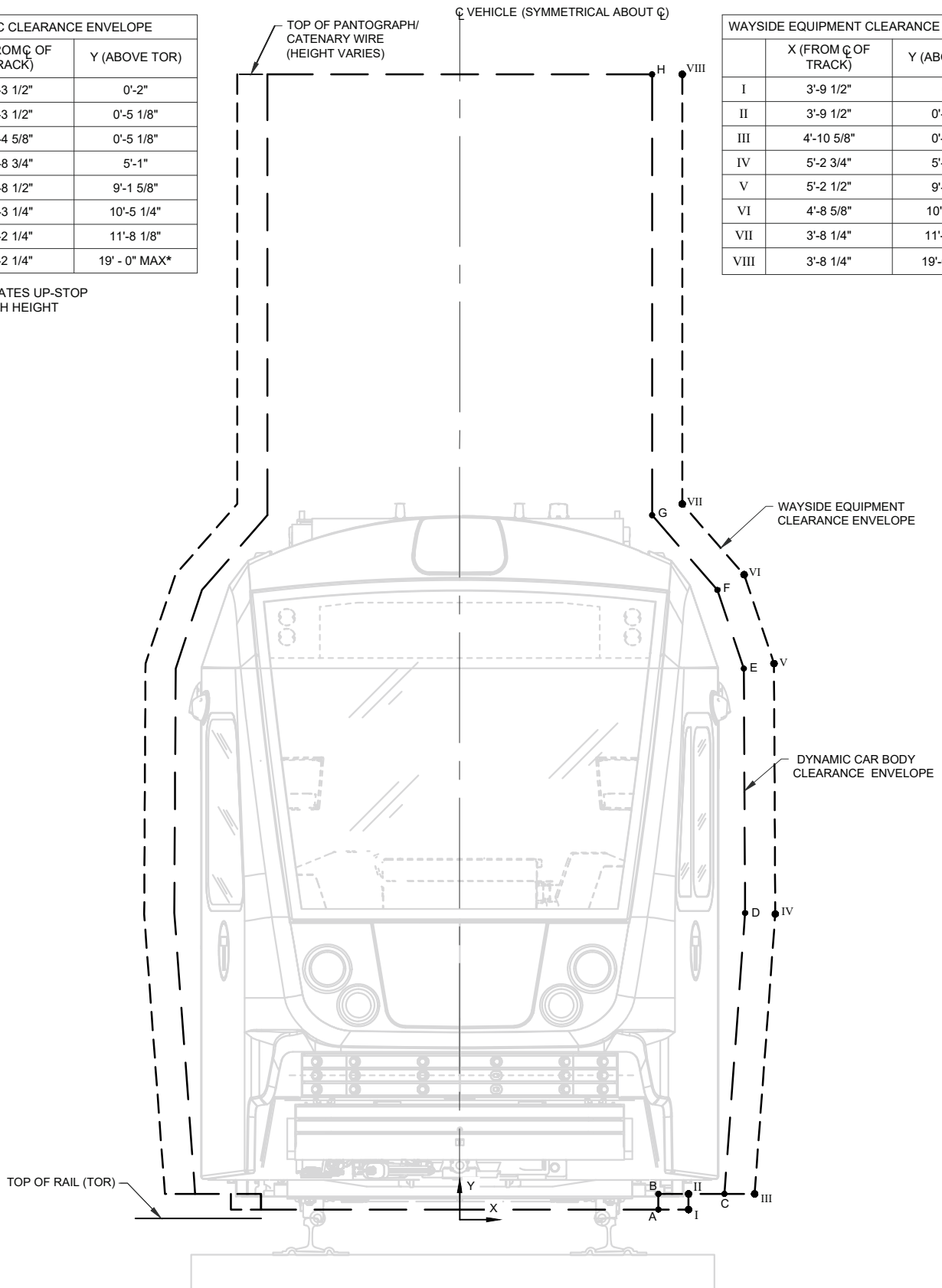

REVENUE VEHICLE DATA SHEET

GREEN LINE TYPE 7, 8, & 9 - CAR BODY CLEARANCE ENVELOPES

DYNAMIC CLEARANCE ENVELOPE		
	X (FROM C OF TRACK)	Y (ABOVE TOR)
A	3'-3 1/2"	0'-2"
B	3'-3 1/2"	0'-5 1/8"
C	4'-4 5/8"	0'-5 1/8"
D	4'-8 3/4"	5'-1"
E	4'-8 1/2"	9'-1 5/8"
F	4'-3 1/4"	10'-5 1/4"
G	3'-2 1/4"	11'-8 1/8"
H	3'-2 1/4"	19' - 0" MAX*

WAYSIDE EQUIPMENT CLEARANCE ENVELOPE		
	X (FROM C OF TRACK)	Y (ABOVE TOR)
I	3'-9 1/2"	0'-2"
II	3'-9 1/2"	0'-5 1/8"
III	4'-10 5/8"	0'-5 1/8"
IV	5'-2 3/4"	5'-0 3/4"
V	5'-2 1/2"	9'-2 5/8"
VI	4'-8 5/8"	10'-8 1/4"
VII	3'-8 1/4"	11'-10 3/8"
VIII	3'-8 1/4"	19'-0" MAX.

*NOTE: INDICATES UP-STOP PANTOGRAPH HEIGHT

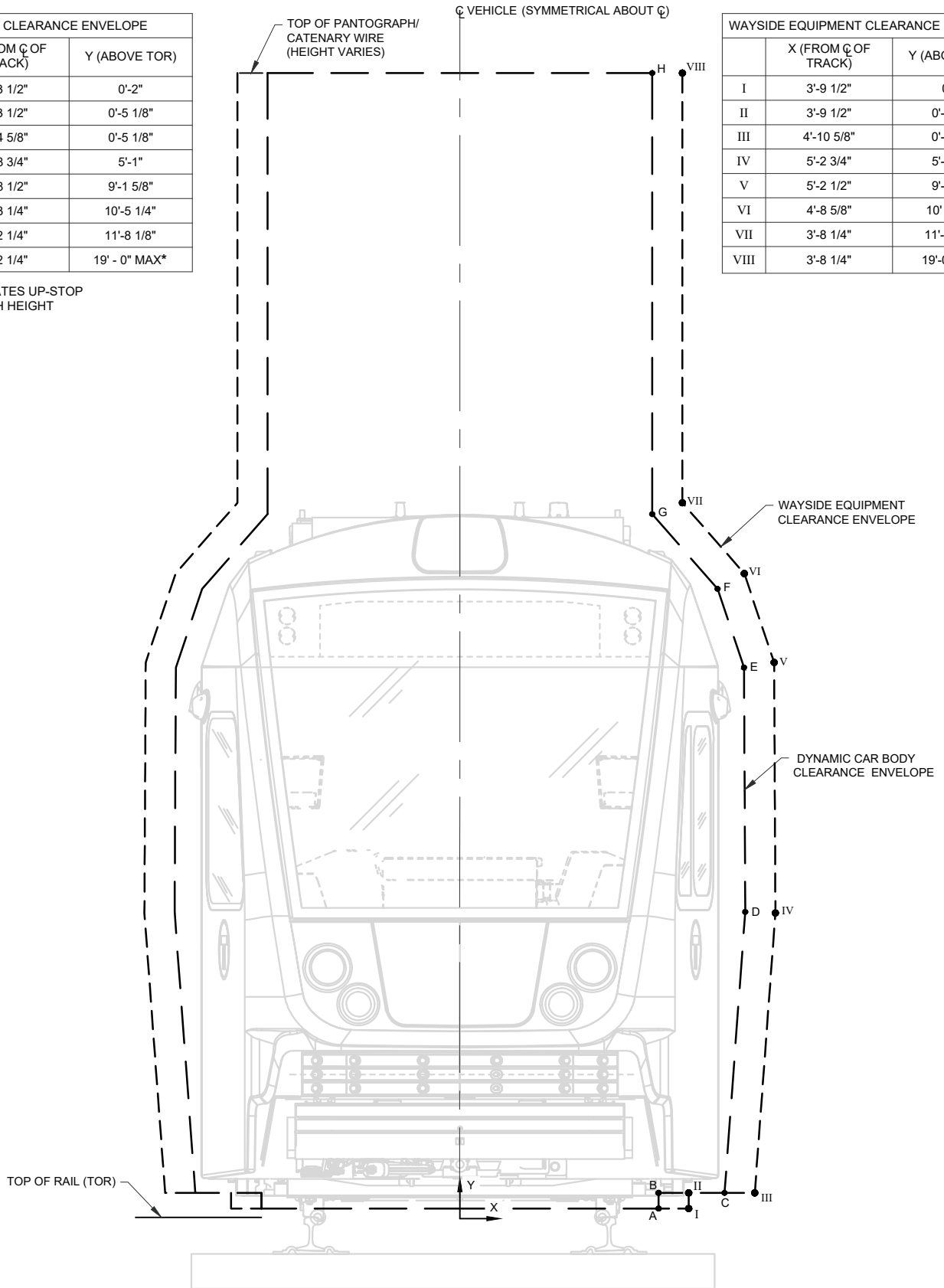

NOTE: SEE TABLE 9 FOR APPLICATION LIMITS.



REVENUE VEHICLE DATA SHEET

GREEN LINE TYPE 10 - CATEGORY 1 CAR BODY CLEARANCE ENVELOPES

DYNAMIC CLEARANCE ENVELOPE		
	X (FROM \bar{C} OF TRACK)	Y (ABOVE TOR)
A	3'-3 1/2"	0'-2"
B	3'-3 1/2"	0'-3 1/2"
C	4'-4 5/8"	0'-3 1/2"
D	4'-4 5/8"	0'-5 1/8"
E	4'-8 3/4"	5'-1"
F	4'-8 1/2"	9'-1 5/8"
G	4'-3 1/4"	10'-5 1/4"
H	3'-2 1/4"	11' - 8 1/8"
I	3'-2 1/4"	19' - 0" MAX*

*NOTE: INDICATES UP-STOP PANTOGRAPH HEIGHT

WAYSIDE EQUIPMENT CLEARANCE ENVELOPE		
	X (FROM \bar{C} OF TRACK)	Y (ABOVE TOR)
I	3'-9 1/2"	0'-2"
II	3'-9 1/2"	0'-3 1/2"
III	4'-10 5/8"	0'-3 1/2"
IV	4'-10 5/8"	0'-5 1/8"
V	5'-2 3/4"	5'-0 3/4"
VI	5'-2 1/2"	9'-2 5/8"
VII	4-8 5/8"	10'-8 1/4"
VIII	3'-8 1/4"	11'-10 3/8"
IX	3'-8 1/4"	19'-0" MAX.

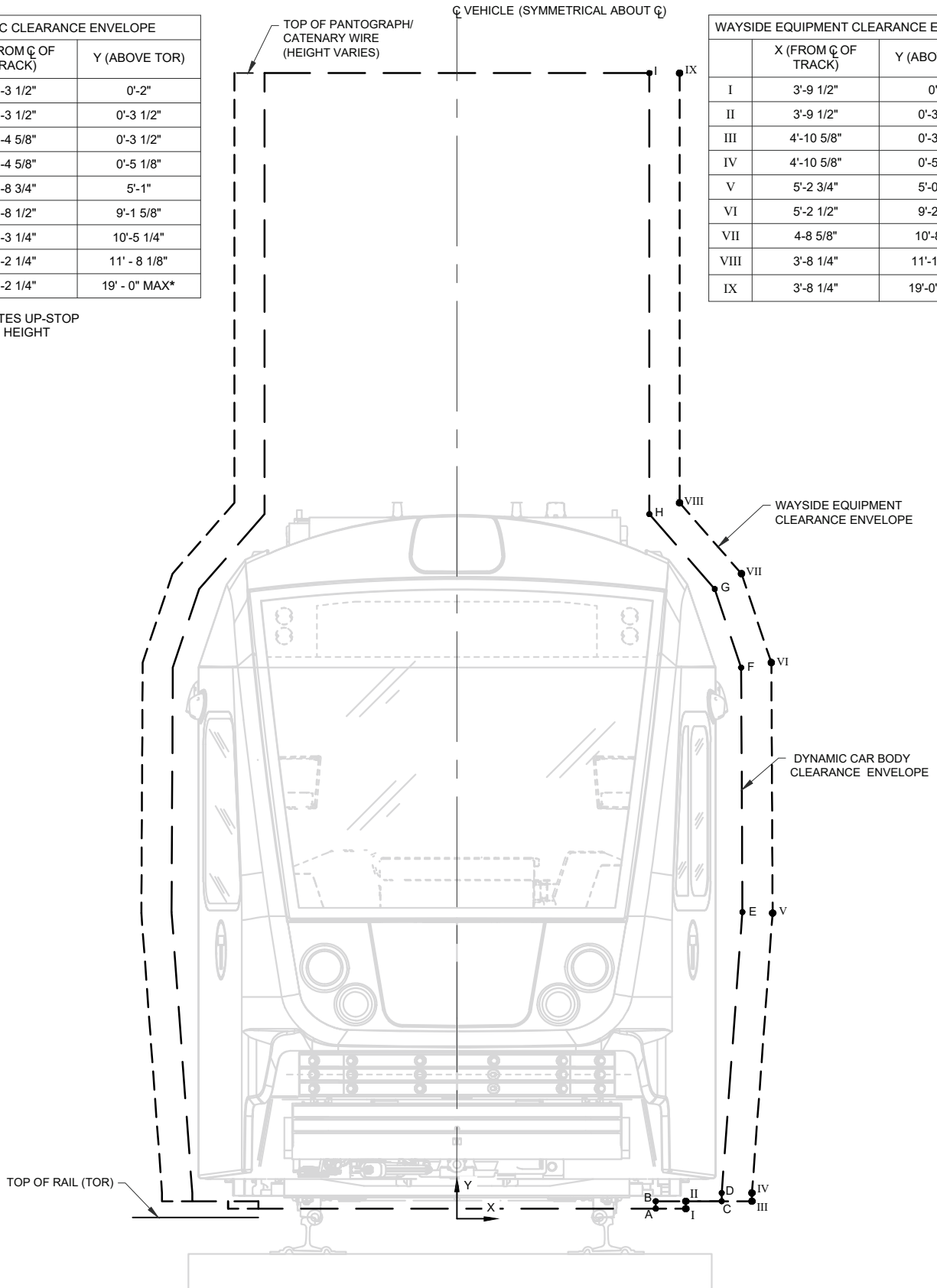

NOTE: SEE TABLE 9 FOR APPLICATION LIMITS.



REVENUE VEHICLE DATA SHEET

GREEN LINE TYPE 10 - CATEGORY 2 CAR BODY CLEARANCE ENVELOPES

DYNAMIC CLEARANCE ENVELOPE		
	X (FROM ϕ OF TRACK)	Y (ABOVE TOR)
A	4'-4 5/8"	0'-2"
B	4'-4 5/8"	0'-5 1/8"
C	4'-8 3/4"	5'-1"
D	4'-8 1/2"	9'-1 5/8"
E	4'-3 1/4"	10'-5 1/4"
F	3'-2 1/4"	11'-8 1/8"
G	3'-2 1/4"	19' - 0" MAX*

WAYSIDE EQUIPMENT CLEARANCE ENVELOPE		
	X (FROM ϕ OF TRACK)	Y (ABOVE TOR)
I	4'-10 5/8"	0'-2"
II	4'-10 5/8"	0'-5 1/8"
III	5'-2 3/4"	5'-0 3/4"
IV	5'-2 1/2"	9'-2 5/8"
V	4'-8 5/8"	10'-8 1/4"
VI	3'-8 1/4"	11'-10 3/8"
VII	3'-8 1/4"	19'-0" MAX.

*NOTE: INDICATES UP-STOP PANTOGRAPH HEIGHT

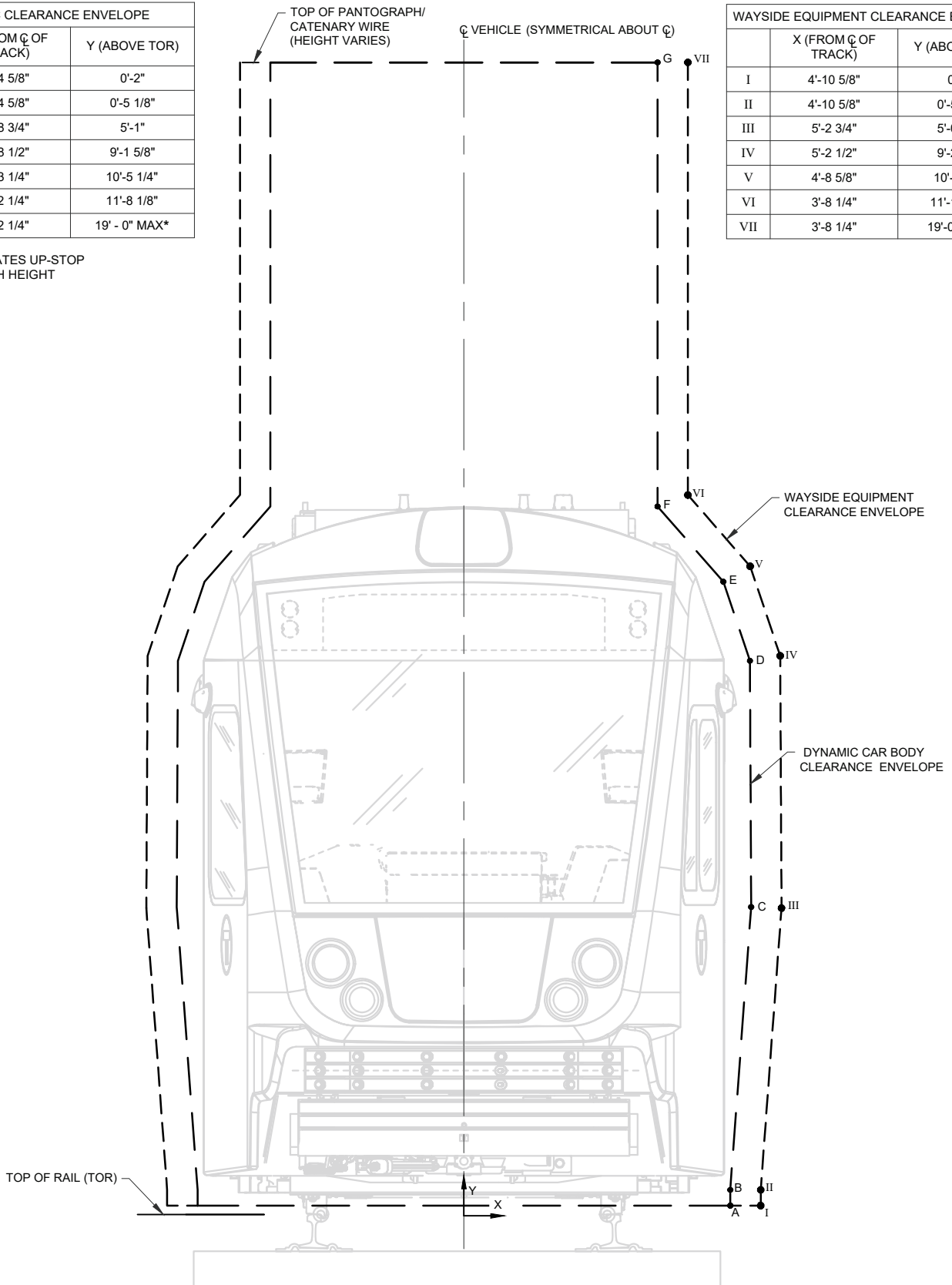

NOTE: SEE TABLE 9 FOR APPLICATION LIMITS.



REVENUE VEHICLE DATA SHEET

GREEN LINE TYPE 10 - CATEGORY 3 CAR BODY CLEARANCE ENVELOPES

DYNAMIC CLEARANCE ENVELOPE		
	X (FROM ϕ OF TRACK)	Y (ABOVE TOR)
A	4'-4 5/8"	0'-0"
B	4'-4 5/8"	0'-5 1/8"
C	4'-8 3/4"	5'-1"
D	4'-8 1/2"	9'-1 5/8"
E	4'-3 1/4"	10'-5 1/4"
F	3'-2 1/4"	11'-8 1/8"
G	3'-2 1/4"	19'-0" MAX*

WAYSIDE EQUIPMENT CLEARANCE ENVELOPE		
	X (FROM ϕ OF TRACK)	Y (ABOVE TOR)
I	4'-10 5/8"	0'-0"
II	4'-10 5/8"	0'-5 1/8"
III	5'-2 3/4"	5'-0 3/4"
IV	5'-2 1/2"	9'-2 5/8"
V	4'-8 5/8"	10'-8 1/4"
VI	3'-8 1/4"	11'-10 3/8"
VII	3'-8 1/4"	19'-0" MAX.

*NOTE: INDICATES UP-STOP PANTOGRAPH HEIGHT

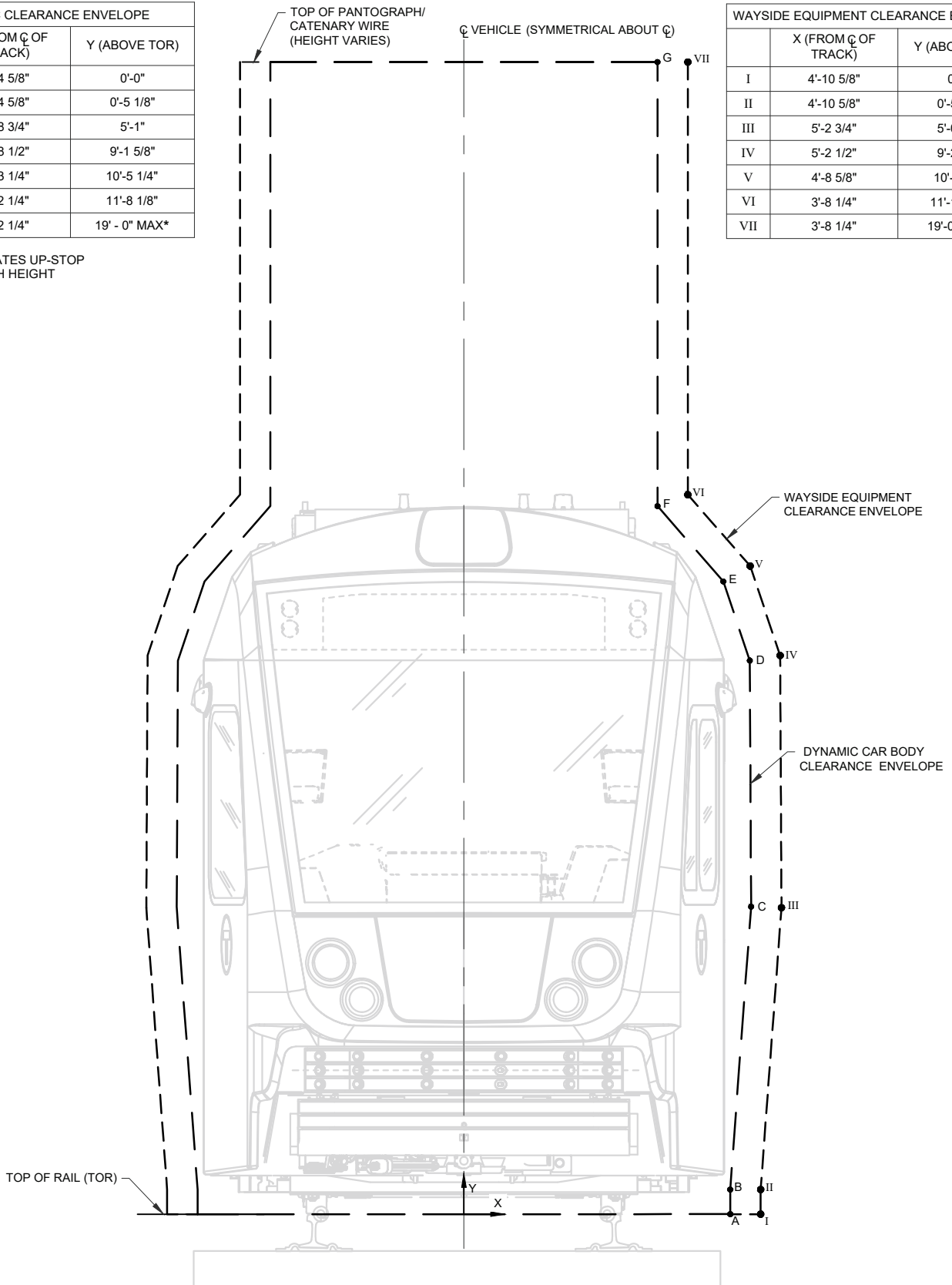

NOTE: SEE TABLE 9 FOR APPLICATION LIMITS.



REVENUE VEHICLE DATA SHEET

GREEN LINE TYPE 10 - CATEGORY 4 CAR BODY CLEARANCE ENVELOPES

DYNAMIC CLEARANCE ENVELOPE		
	X (FROM ϕ OF TRACK)	Y (ABOVE TOR)
A	3'-11 1/4"	0'-2"
B	3'-11 1/4"	0'-4 1/2"
C	4'-0 5/8"	0'-4 1/2"
D	4'-4 5/8"	0'-5 1/8"
E	4'-4 5/8"	0'-5 1/8"
F	4'-8 3/4"	5'-1"

WAYSIDE EQUIPMENT CLEARANCE ENVELOPE		
	X (FROM ϕ OF TRACK)	Y (ABOVE TOR)
I	4'-5 1/4"	0'-2"
II	4'-5 1/4"	0'-4 1/2"
III	4'-6 5/8"	0'-4 1/2"
IV	4'-6 5/8"	0'-5 1/8"
V	4'-10 5/8"	0'-5 1/8"
VI	5'-2 3/4"	5'-1"

ϕ VEHICLE (SYMMETRICAL ABOUT ϕ)

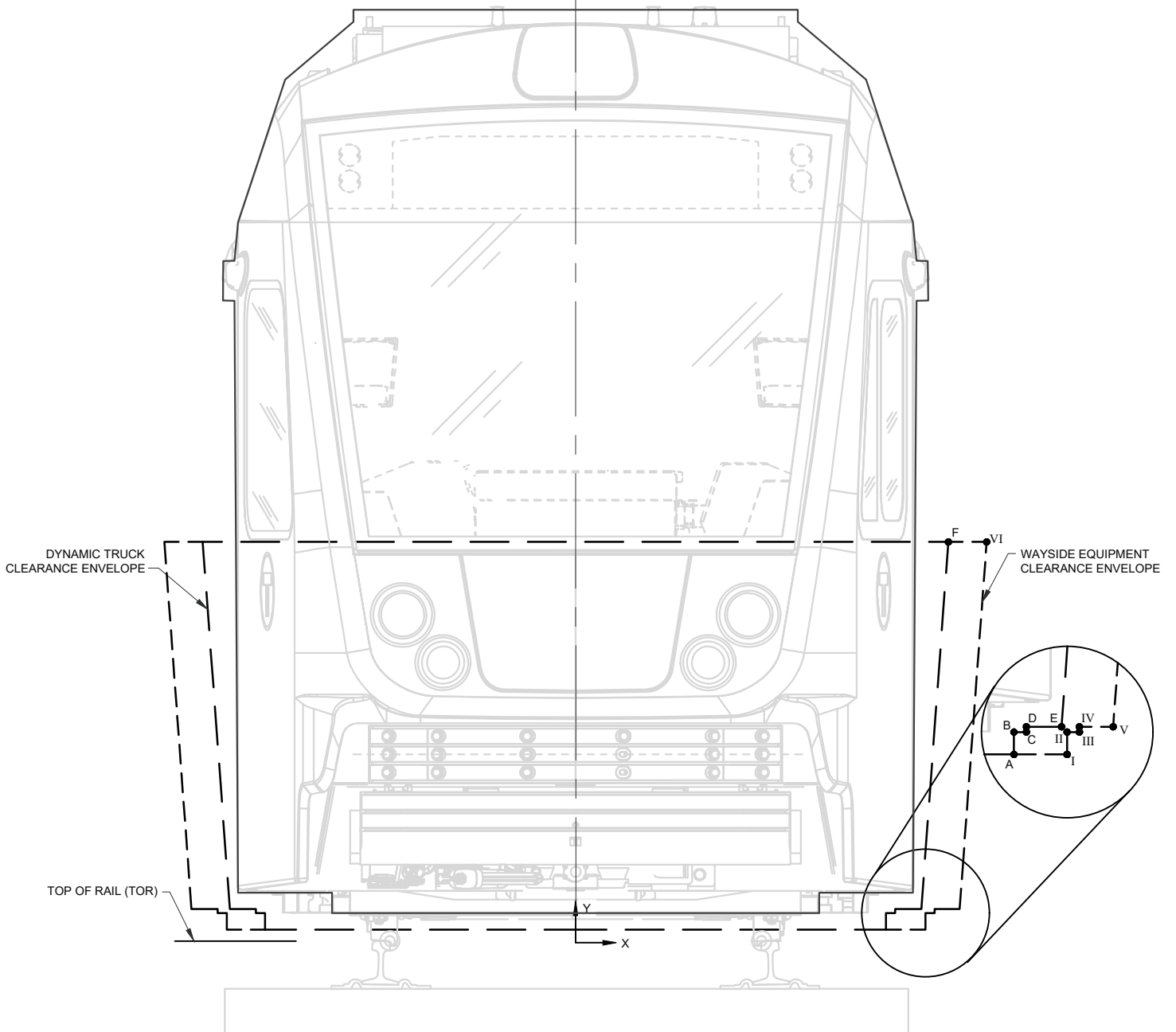

REVENUE VEHICLE DATA SHEET

GREEN LINE TYPE 10 - TRUCK CLEARANCE ENVELOPES

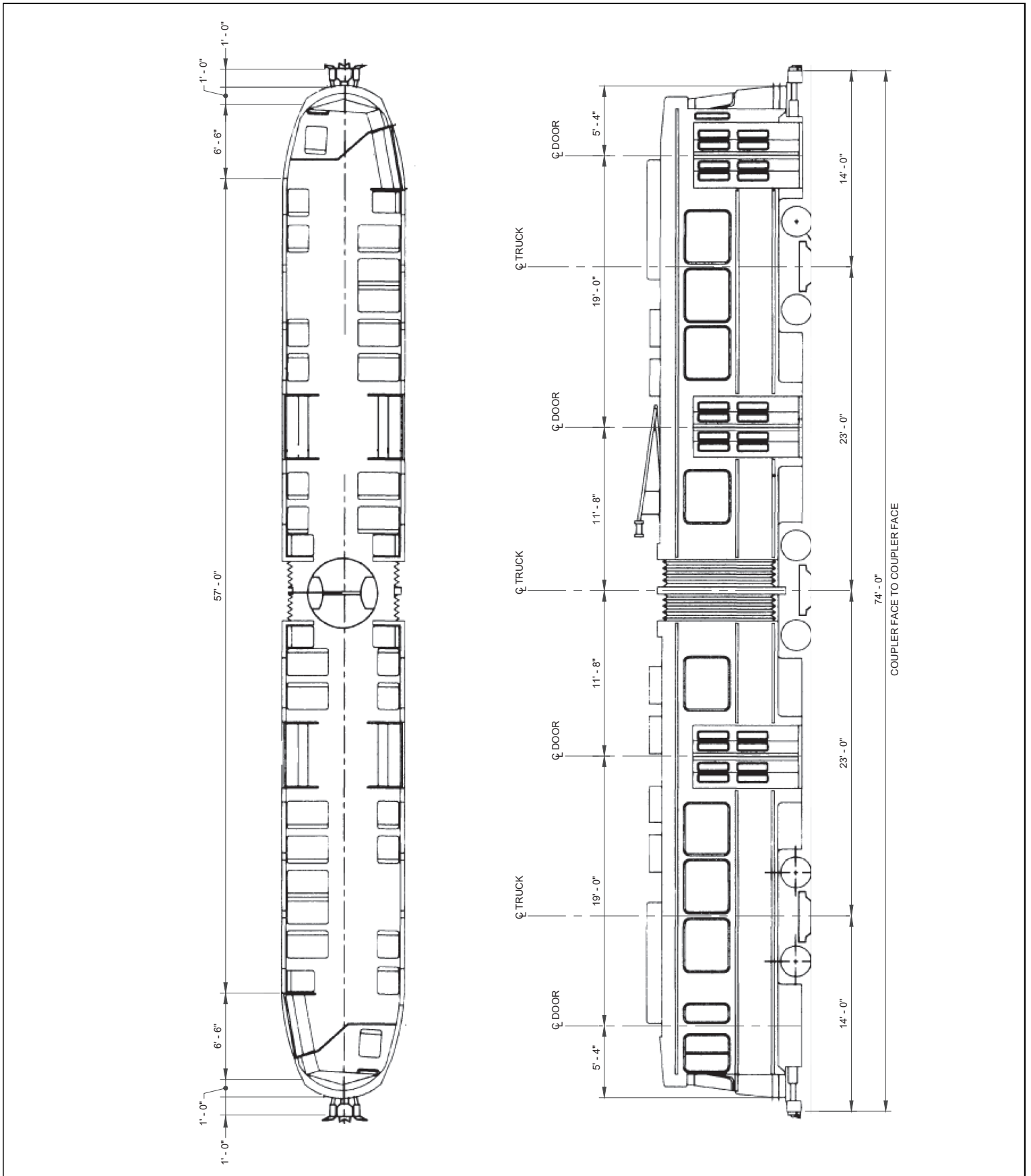

REVENUE VEHICLE DATA SHEET

GREEN LINE TYPE 7 - GENERAL ARRANGEMENT

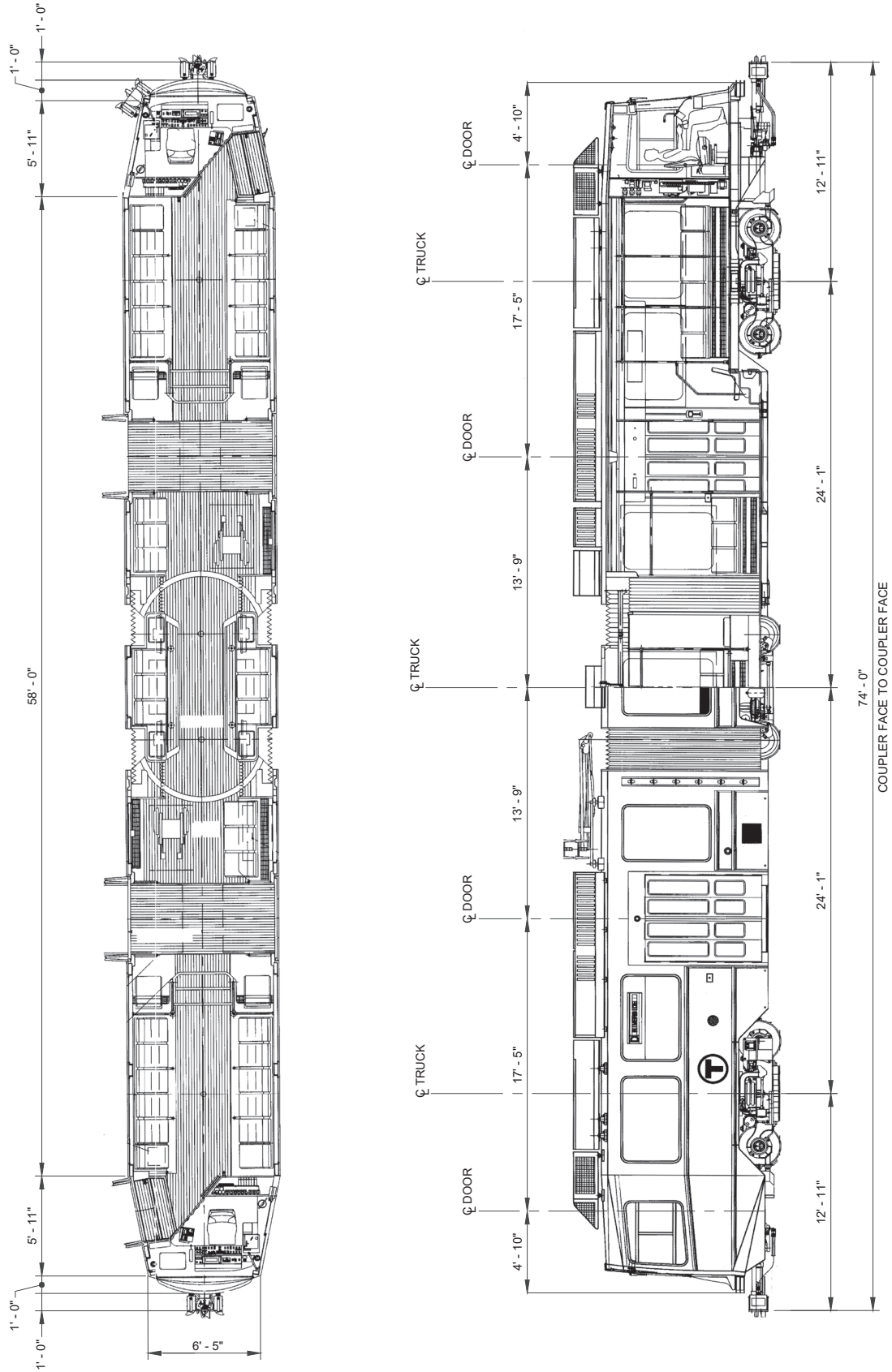

REVENUE VEHICLE DATA SHEET

GREEN LINE TYPE 8 - GENERAL ARRANGEMENT

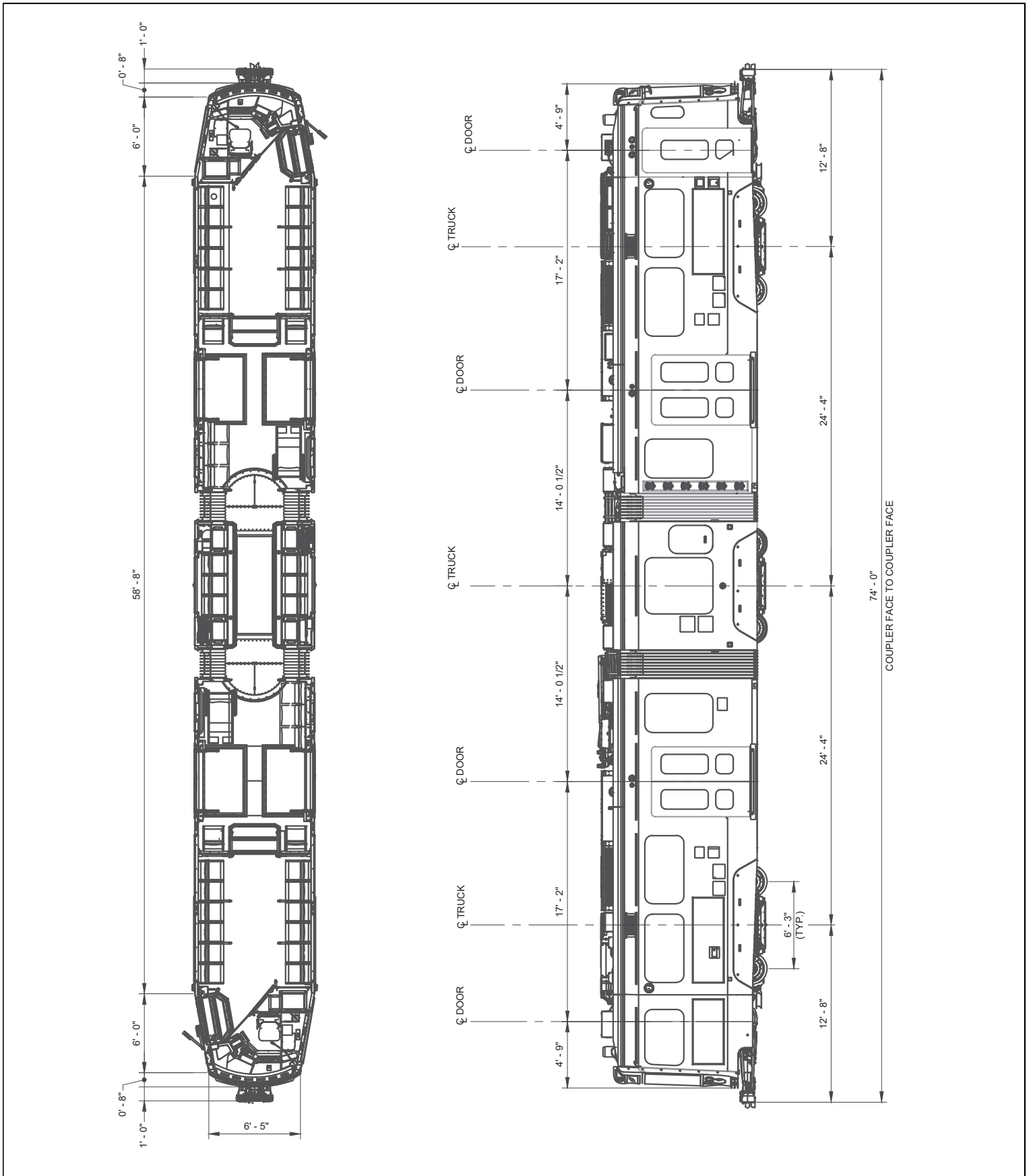

REVENUE VEHICLE DATA SHEET

GREEN LINE TYPE 9 - GENERAL ARRANGEMENT

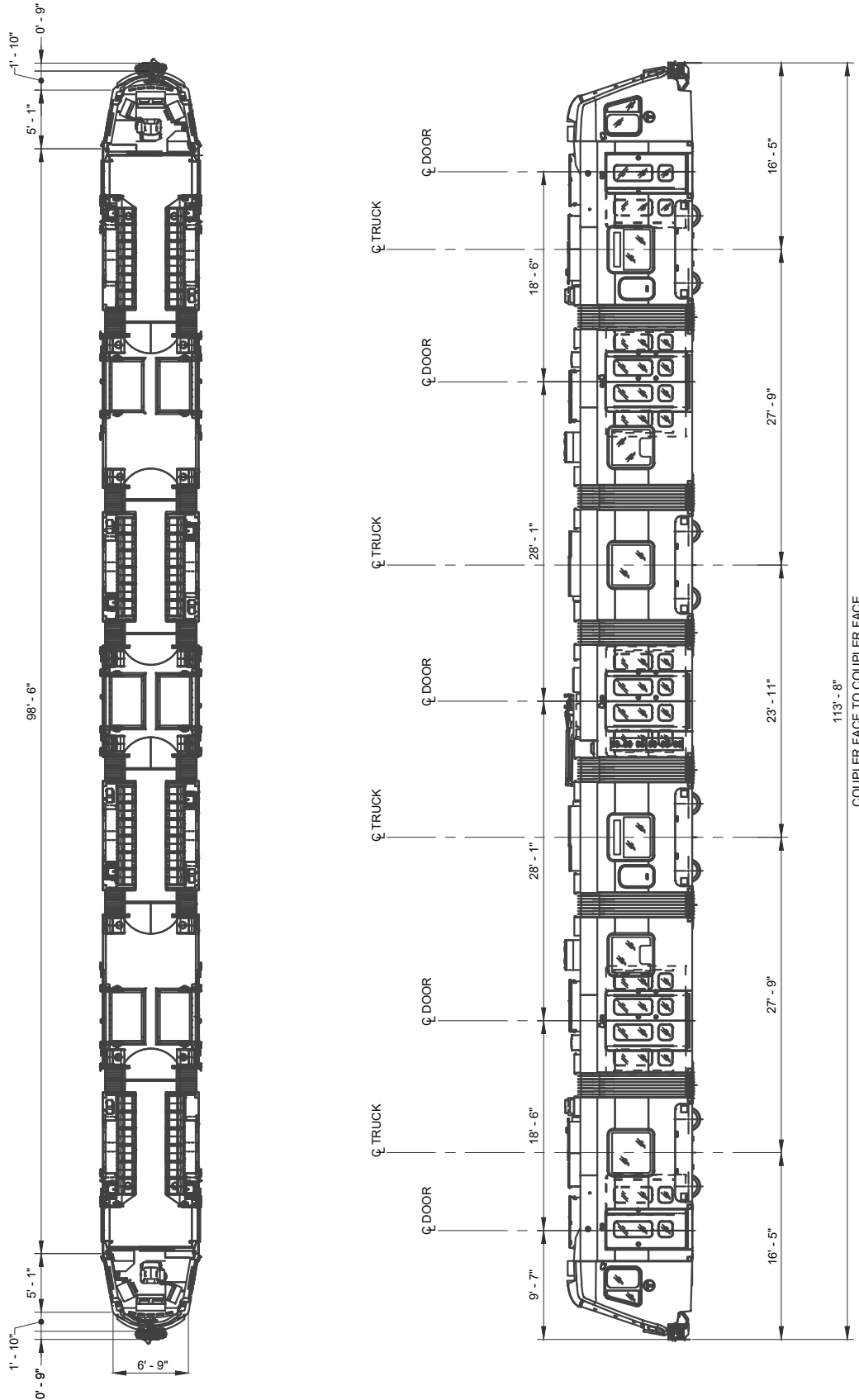

REVENUE VEHICLE DATA SHEET

GREEN LINE TYPE 10 - GENERAL ARRANGEMENT

Radius of Track (ft)	Type 7, 8, & 9		Type 10	
	Center Excess (CE) (in)	End Excess (EE) (in)	Center Excess (CE) (in)	End Excess (EE) (in)
50	17 1/4	23 1/2	4 3/8	12 3/8
75	11 1/2	11 3/8	3	6 1/8
100	8 1/2	8 1/2	2 1/4	4 3/4
125	6 7/8	6 7/8	1 3/4	3 7/8
150	5 5/8	5 5/8	1 1/2	3 1/4
175	4 7/8	4 7/8	1 3/8	2 3/4
200	4 1/4	4 1/4	1 1/8	2 1/2
225	3 3/4	3 3/4	1	2 1/4
250	3 3/8	3 3/8	1	2
300	2 3/4	2 7/8	3/4	1 5/8
400	2 1/4	2 1/8	5/8	1 1/4
500	1 5/8	1 5/8	1/2	1
600	1 3/8	1 3/8	3/8	7/8
750	1 1/8	1 1/8	3/8	3/4
1,000	7/8	7/8	1/4	1/2
1,500	5/8	5/8	1/4	3/8
2,000	1/2	1/2	1/8	1/4
3,000	1/4	1/4	1/8	1/4



REVENUE VEHICLE DATA SHEET

GREEN LINE TYPE 7, 8, 9, & 10 - CAR BODY EXCESS TABLE